

K107B Serial port electric connections

X-side serial port: half-duplex RS232

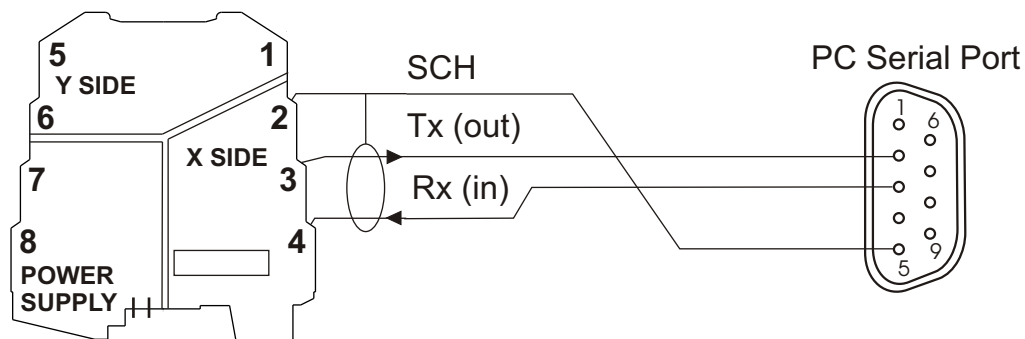

Y-side serial port: half-duplex RS485

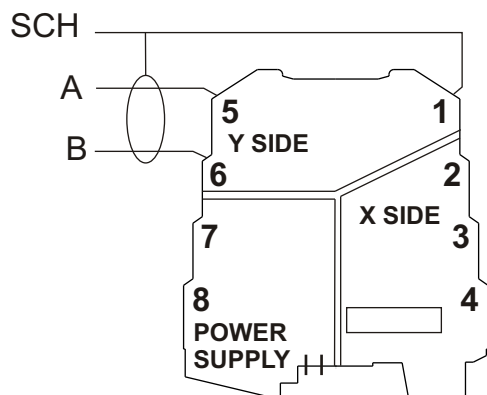

The use of screened cables is always recommended, and especially whenever the length of the connections is greater than 3 m

This document is property of SENECA srl. Duplication and reproduction are forbidden, if not authorized. Contents of the present documentation refers to products and technologies described in it. All technical data contained in the document may be modified without prior notice Content of this documentation is subject to periodical revision.

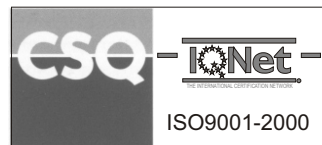

Brought to you by **SENECAUK**
PO Box 1 - Ilkley - West Yorkshire - LS29 8EU
Tel:01943 816796 - Fax: 01943 816796
Web: www.SenecaUK.com - Email: sales@SenecaUK.com



K107A / K107B

Half-duplex RS485 serial bus with 3-point insulation

General Description

The K107A and K107B modules are half duplex serial buses with 3-point insulation. Although both modules feature:

- Timed automatic direction switching.
- Communication speeds that can be configured by dip-switch,

They differ in the type of interface present on the X side:

K107A: RS485

K107B: RS232B



Technical features

Power supply features

Power-supply :	19,2..30 Vdc
Consumption :	max 22 mA at 24 Vdc under normal operating conditions.

X-side port characteristics

Type:	K107A :RS485, K107B: RS232B
Capacity:	32 standard nodes for K107A
Terminator:	Yes for K107 A, No for K107B
Protection:	Up to 30 Vdc

Y-side port characteristics

Type:	RS485 half-duplex
Capacity:	32 standard nodes
Terminator:	Yes
Protection:	Up to 30 Vdc

Signal transmission/processing characteristics

Handshake :	Timed automatic
Insulation :	Optical
Speed :	1200...115200 bps
Configuration :	by dip-switch
Other functions available :	X or Y side terminator, X->Y or Y->X communication direction inhibition

General Technical Features

Insulation voltage :	1.5 kV between each pair of ports
Protection :	IP20
Environmental conditions :	Temperature: -20 ... +65°C Humidity: 10 ... 90% non-condensing Altitude: up to 2000 m. a. s. l.
Storage temperature:	-40..+85 °C
Dissipation:	Lower than 500 mW
Signalling by LED :	Data Presence on X port, Data presence on Y port, inverted connection on X port and inverted connection on Y port.
Connections :	Cable clamp terminals and bus (rear connector for DIN and K-BUS bar)
Wire section :	0,2..2,5 mm ²
Wire stripping :	8 mm
Box :	PBT, black
Dimensions and weight :	6,2 x 93,1 x 102,5 mm, 46 g.
Reference standards :	EN61000-6-4/2002 (electromagnetic emission, industrial environment) EN61000-6-2/2005 (electromagnetic immunity, industrial environment) EN61010-1/2001 (safety). All circuits must be insulated from the other circuits under dangerous voltage with double insulation. The power supply transformer must comply with EN60742: "Insulated transformers and safety transformers".



K107A Serial port electric connections

X-side serial port: half-duplex RS485

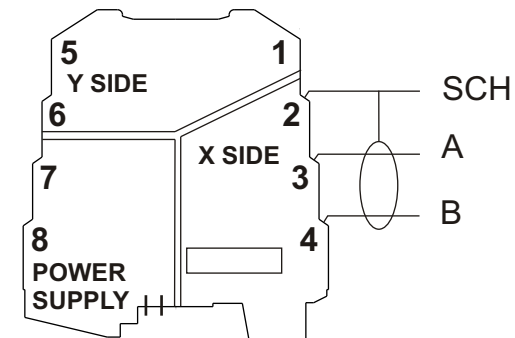

Y-side serial port: half-duplex RS485

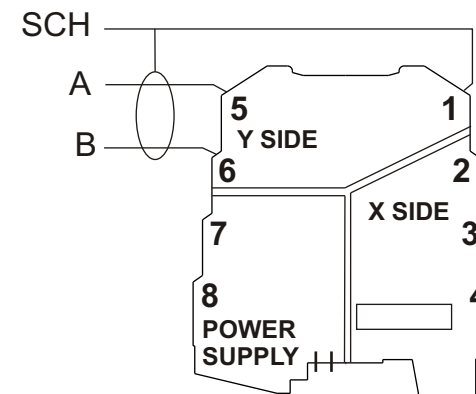

The use of screened cables is always recommended, and especially whenever the length of the connections is greater than 3 m.

Electrical Connections

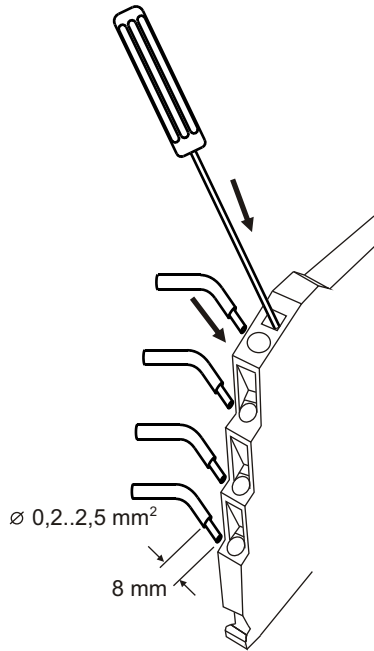

The module has been designed for spring-type terminal electrical connections.

Proceed as follows to make the connections:

- 1 - Strip the cables by 0.8 mm
- 2 - Insert a screwdriver in the square hole and press it until the cable lock spring opens.
- 3 - Insert the cable in the round hole.
- 4 - Remove the screwdriver and make sure that the cable is tightly fastened in the terminal.

Power supply

There are various ways to provide the K Series modules with power.

- 1 - Direct power supply to the modules by connecting 24 Vdc power supply directly to Terminals 7 (+) and 8 (-) of each module.

- 2 - Using the K-BUS connector accessory for the distribution of the power supply to the modules via bus connector, in this way eliminating the need to connect power supply to each module.

The bus can be supplied from any of the modules; the total absorption of the bus must be less than 400 mA. Higher absorption values can damage the module. An appropriately sized fuse must be connected in series to the power supply.

- 3 - Using the K-BUS connector accessory for the distribution of the power supply to the modules via bus connector and the K-SUPPLY accessory for the connection of the power supply.

The K-SUPPLY accessory is a 6.2 mm wide module that contains a set of protections designed to protect the modules connected via bus against over-voltage loads.

The bus connector can be provided with power using the K-SUPPLY module if the total absorption of the bus is less than 1.5 A. Higher absorption values can damage both the module and the bus. An appropriately sized fuse must be connected in series to the

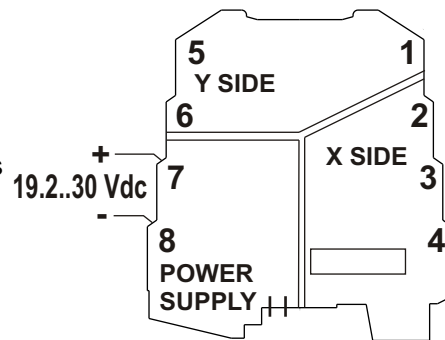

Description of operation

The device usually stays with both its communication ports in reception state (idle status); the first transition (character) detected at one of the ports enables the corresponding communication channel, while the opposing port becomes the data outlet by repeating the stream (data flow) received on the first. Whenever the data flow is interrupted, after a period of time depending on the communication speed set, the device returns to its previous state of reception on both ports (idle status). The time for return to idle status is usually around 1.5 characters starting from the reception line's last active status; in any case however, a different period of time can be selected whenever required by protocol. The table below indicates switching times on the basis of the transmission speed set:

Speed (bps)	Switching time (ms)
115220	0,13
57600	0,26
38400	0,39
19200	0,78
9600	1,56
4800	3,13
2400	6,25
1200	12,5

Two modules can be used as insulator or repeater for a Full-Duplex connection. In this case, it is useful that the module installed on the master's Tx line inhibit communication direction by selecting either the X->Y direction or the Y->X direction; although switching both dip-switches ON does not cause malfunctions, it inhibits the device with both ports in transmission.

Signalling by LED on the front panel

LED	Meaning
Green Led on X side	Flashing: data presence at X-port. Steady: inverted connection at X port or X -> Y direction inhibition enabled.
Green Led on Y side	Flashing: data presence at Y-port. Steady: inverted connection at Y port or Y -> X direction inhibition enabled.
Central Green Led	A blink of the LED when the device is turned on indicates the presence of voltage.

DIP-SWITCH SETTINGS

Both the K107 A and K107 B modules can be completely configured by dip-switches. The meaning of the possible dip-switch settings is provided below.

In all the following tables, the indication ● means that the DIP-switch is set in 1 (ON); whenever no such indication is provided, it means that the DIP-switch is set in 0 (OFF).

X->Y DIRECTION INHIBITION		
SW1	1	
		● Enabled
		Disabled

Y Terminator		
SW1	2	
		● Enabled
		Disabled

Transmission speed				
SW2	3	4	5	
				115200
	●			57600
		●		38400
	●	●		19200
			●	9600
	●	●		4800
		●	●	2400
	●	●	●	1200

Y->X DIRECTION INHIBITION		
SW1	6	
		● Enabled
		Disabled

X Terminator (only for the K107A)		
SW1	7	
		● Enabled
		Disabled

Polarizer * (only for the RS232 of the K107 B)		
SW1	8	
		● Enabled
		Disabled

* When installed, the polarizer prevents the RS232 line from capturing noise when left disconnected

Installation rules

This module has been designed for assembly on a DIN 46277 rail. Assembly in vertical position is recommended in order to increase the module's ventilation, and no raceways or other objects that compromise aeration must be positioned in the vicinity.

Do not position the module above equipment that generates heat; we recommend positioning the module in the lower part of the control panel or container compartment. We recommend rail-type assembly using the corresponding bus connector (Code K-BUS) that eliminates the need to connect the power supply to each module.

Inserting the module in the rail

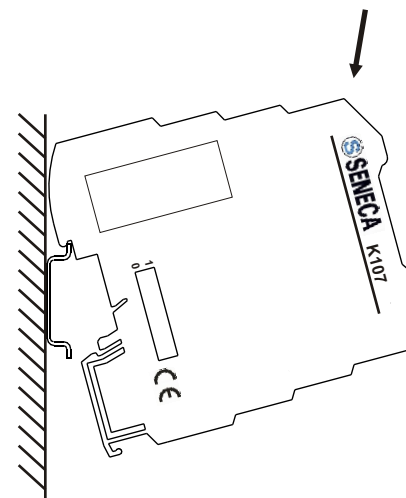

- 1 - Attach the module in the upper part of the rail.
- 2 - Press the module downwards.

Removing the module from the rail

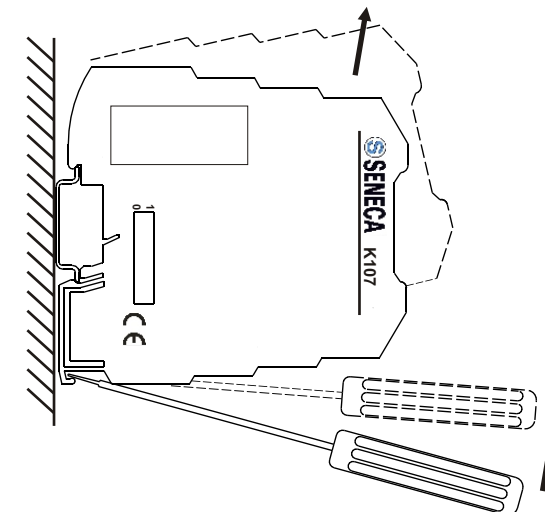

- 1 - Apply leverage using a screwdriver (as shown in the figure).
- 2 - Rotate the module upwards.

Using the K-BUS connector

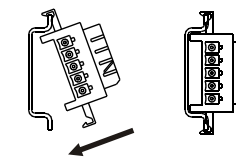
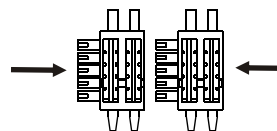

- 1 - Compose the K-BUS connectors as required in order to obtain the number of positions necessary (each K-BUS permits the insertion of no. 2 modules).
- 2 - Insert the K-BUS connectors in the rail by positioning them on the upper side of the rail and then rotating them downwards.

IMPORTANT: Pay particular attention to the position of the protrudent terminals of the K-BUS. The K-bus must be inserted in the guide with the protrudent terminals on the left (as shown in the figure) otherwise the modules are turned upside downs.



- Never connect the power supply directly to the bus connector on the DIN rail.
- Never tap power supply from the bus connector either directly or by using the module's terminals.