



# K109TC

## TEMPERATURE-INSULATED CONVERTER FOR THERMOCOUPLES

### General Description

The K109TC instrument is a 4-point galvanic insulator. It converts a temperature signal read by a thermocouple into a signal normalised in voltage or current; besides it has a passive output which commutates at the overcoming of a threshold set through a button on the front.

The module's main features are its compact size (6.2 mm), attachment to a 35 mm DIN rail, bus-connector power supply option, quick connection by spring terminals, and easy configuration in the field by DIP-switch.



### Technical Features

Power supply :	19,2..30 Vdc
Consumption :	max 24 mA at 24 Vdc
Input :	Thermocouples types: J, K, E, N, S, R, B, T
Tables :	EN60584-1 (ITS-90)
Measurement Range :	Depending on the thermocouple type (see <i>Range and Precision of the Input Table</i> ), on the dip-switches selection (see <i>Setting of the Dip-Switches</i> section)
Minimum span :	100 °C
Impedance :	10 MW
Test Current :	<50 nA
CMRR <sup>(1)</sup> :	>135 dB, referred to power-supply side
DMRR <sup>(1)(2)</sup> :	>40 dB

<sup>(1)</sup> The values are valid at the set rejection frequency, with filter ON.

<sup>(2)</sup> For disturbance values such as the input signal peak does not exceed the limit of acceptability.

Range and Precision of the Input			
Thermocouple	Admitted Range	Mean Error	Resolution
J	-210..1200 °C	0,025 % + 0,29 °C	0,12 °C
K	-200..1372 °C	0,025 % + 0,4 °C	0,17 °C
E	-200..1000 °C	0,025 % + 0,2 °C	0,92 °C
N	-200..1300 °C	0,025 % + 0,42 °C	0,19 °C
S	-50..1768 °C	0,025 % + 1,34 °C	0,66 °C
R	-50..1768 °C	0,025 % + 1,19 °C	0,59 °C
B	250..1820 (*)°C	0,025 % + 1,87 °C	0,9 °C
T	-200..400 °C	0,025 % + 0,31 °C	0,13 °C

(\*): Up to 250 °C, the output is considered equivalent to a null temperature.

The bus connector can be provided with power using the K-SUPPLY module if the total absorption of the bus is less than 1.5 A. Higher absorption values can damage both the module and the bus. An appropriately sized fuse must be connected in series to the power supply.

### Input

The module accepts input from the following types of thermocouples: J, K, E, N, S, R, B, T.

The use of shield cables is recommended for the electronic connections.

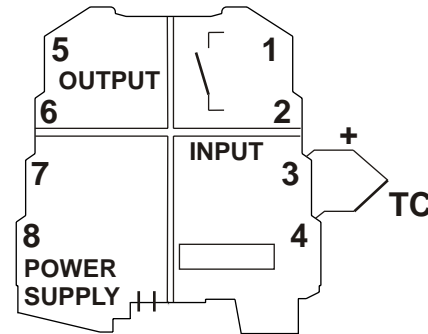

### Output

Voltage connection - Current connection (applied current)

The use of shield cables is recommended for the electronic connections.

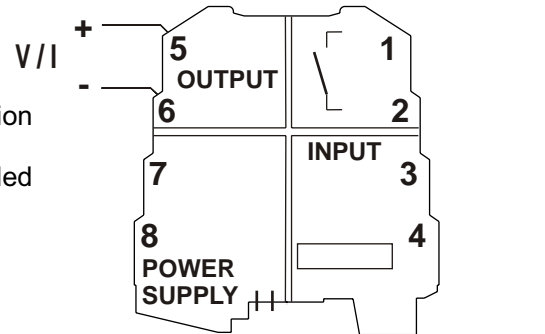

### Auxiliary Output

The auxiliary output has been designed to pilot an indicator or a relay of greater power or the input of a supervisor control system.

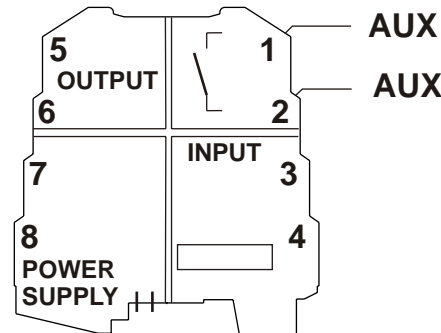

This document is property of SENECA srl. Duplication and reproduction are forbidden, if not authorized. Contents of the present documentation refers to products and technologies described in it. All technical data contained in the document may be modified without prior notice Content of this documentation is subject to periodical revision.



Brought to you by **SENECAUK**  
PO Box 1 - Ilkley - West Yorkshire - LS29 8HS  
Tel: 01943 602001 - Fax: 01943 816796  
Web: www.SenecaUK.com - Email: sales@SenecaUK.com

Voltage Output :	0..5 Vdc, 1..5 Vdc, 0..10 Vdc e 10..0 Vdc Minima load resistance 2 kO
Current Output :	0..20 mA, 4..20 mA, 20..0 mA e 20..4 mA Maximum load resistance 500 O
Maximum Voltage :	approximately 12,5 V
Maximum Current :	approximately 25 mA
Resolution :	1 mV for voltage output, 2 mA for current output
Error :	mA or 5 V out put: 350 ppm of the end scale 10 V output : 200 ppm of the end scale

Static Aux Output :	Applicable Voltage : 24 Vac Nominal Current: 60 mA Max
---------------------	---

ADC :	14 bits
Class/Base Prec. :	0,1 %
Thermal Drift :	120 ppm/K
Response Time : (10..90 %):	< 25 ms (without filter) < 55 ms (with repeat filter 50 Hz)
Cold junction error :	1,5 °C Max

Insulation Voltage :	1,5 kV (50 Hz for 1 min)
Protection Index :	IP20
Operating Conditions :	Temperature -20..+65 °C Humidity 10..90 % at 40 °C non-condensing.
Storage Temperature :	-40..+85 °C
Altitude :	Up to 2000 slm
LED Signalling :	Fault/Anomaly, state of the auxiliary output
Connections :	Spring terminals
Conductor Section :	0,2..2,5 mm <sup>2</sup>
Wire stripping :	8 mm

Box :	PBT (black colour)
Dimensions, Weight :	6,2 x 93,1 x 102,5 mm, 46 g.

Standards :	EN61000-6-4/2002 (electromagnetic emission, industrial surroundings) EN61000-6-2/2005 (electromagnetic immunity, industrial surroundings) EN61010-1/2001 (safety) All the circuits must be provided with double insulation from the circuits under dangerous voltage. The power supply transformer must be built to compliance with EN60742: "Insulation transformers and Safety transformers".
-------------	--

Yellow LED	Meaning
ON	The auxiliary output is closed
OFF	The auxiliary output is opened

### Electrical Connections

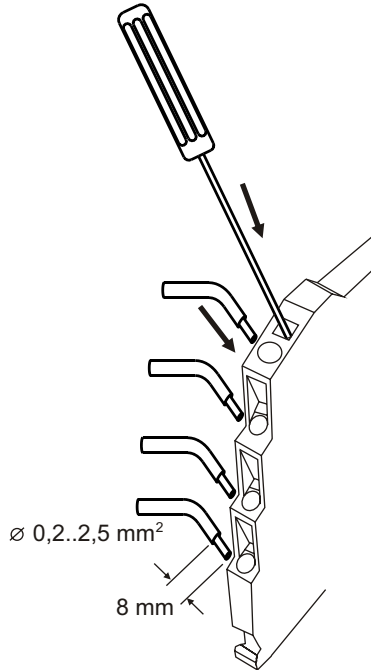

The module has been designed for spring-type terminal electrical connections.

Proceed as follows to make the connections:

- 1 - Strip the cables by 0.8 mm
- 2 - Insert a screwdriver in the square hole and press it until the cable lock spring opens.
- 3 - Insert the cable in the round hole.
- 4 - Remove the screwdriver and make sure that the cable is tightly fastened in the terminal.

### Power supply

There are various ways to provide the K Series modules with power.

- 1 - Direct power supply to the modules by connecting 24 Vdc power supply directly to Terminals 7 ( + ) and 8 ( - ) of each module.

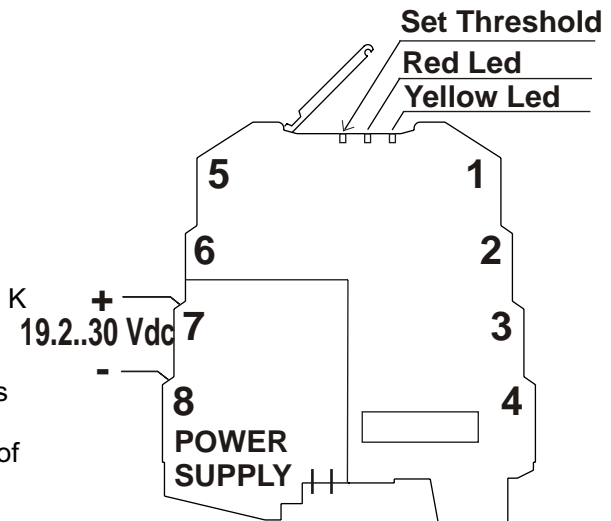

- 2 - Using the K-BUS connector accessory for the distribution of the power supply to the modules via bus connector, in this way eliminating the need to connect power supply to each module.

The bus can be supplied from any of the modules; the total absorption of the bus must be less than 400 mA. Higher absorption values can damage the module. An appropriately sized fuse must be connected in series to the power supply.

- 3 - Using the K-BUS connector accessory for the distribution of the power supply to the modules via bus connector and the K-SUPPLY accessory for the connection of the power supply. The K-SUPPLY accessory is a 6.2 mm wide module that contains a set of protections designed to protect the modules connected via bus against over-voltage loads.

MEASUREMENT RANGE END											
SW2	1	2	3	J Type	K Type	R Type	Type S	T Type	B Type	E Type	N Type
				1200 °C	1350 °C	1750 °C	1750 °C	400 °C	1800 °C	1000 °C	1300 °C
	●			1000 °C	1200 °C	1500 °C	1500 °C	350 °C	1600 °C	800 °C	1200 °C
		●		800 °C	1000 °C	1300 °C	1300 °C	300 °C	1500 °C	600 °C	1000 °C
			●	600 °C	800 °C	1100 °C	1100 °C	250 °C	1300 °C	500 °C	800 °C
			●	500 °C	700 °C	900 °C	900 °C	200 °C	1100 °C	400 °C	600 °C
	●		●	400 °C	500 °C	700 °C	700 °C	150 °C	900 °C	300 °C	500 °C
		●	●	300 °C	300 °C	500 °C	500 °C	100 °C	700 °C	200 °C	400 °C
	●	●	●	200 °C	200 °C	300 °C	300 °C	50 °C	500 °C	100 °C	200 °C

OUTPUT			
SW2	4	5	6
			4..20 mA
	●		0..20 mA
		●	20..4 mA
	●	●	20..0 mA
		●	0..10 V
	●	●	1..5 V
		●	10..0 V
	●	●	0..5 V

OUTPUT SIGNAL IN CASE OF FAULT	
SW2	7
	● Towards the bottom of the output range
	● Towards the top of the output range

OVER-RANGE (*)	
SW2	8
	● NO: the malfunction alone causes a 2.5% over-range value.
	● YES: a 2.5% over-range value is acceptable; a 5% over-range value is considered a malfunction.

(\*) See the table below for the corresponding values.

#### Output Signal Limits

Nominal Value	Over-range ± 2,5 %	Over-range ± 5 %
20 mA	20,5 mA	21 mA
4 mA	3,5 mA	3 mA
0 mA	0 mA	0 mA
10 Vdc	10,25 Vdc	10,5 Vdc
5 Vdc	5,125 Vdc	5,25 Vdc
1 Vdc	0,875 Vdc	0,75 Vdc
0 Vdc	0 Vdc	0 Vdc

#### LED indications on the front

Red LED	Meaning	Output Fault
Fast flashing	Internal fault: power supply not sufficient, out of range offset or reference . Error on reading or writing in flash (at the start or on threshold setting)	YES
Slow flashing	DIP-switch setting error	YES
	Set Threshold in progress	NO (*)
Steady light	Disconnected thermocouple, out of range input or temperature compensation	YES
	Output limiting in progress	NO

(\*): In this modality the output signal represents the value of the threshold.

## AUXILIARY OUTPUT

### Description

The auxiliary output has been designed in order to pilot an indicator, a relay of greater power or the input of a supervisor control system. Through this output the K109 TC instrument may generate an alarm or may be utilized like a thermostat. The **Normal** state of the output depends on the configuration for the fault of the primary output, so on the setting of the correspondent dip-switch SW2.7 (see *Details of Dip-Switch SW2.7* table). Since during the regulation of the threshold the primary output assumes the value of the threshold, it is advisable to connect an instrument of measure (a multimeter for example) to the primary output. Therefore the value in V or mA of the threshold depends on the scale of the chosen output. The switching is instantaneous to the overcoming of the set up value.

### Setting of the threshold

The regulation of the threshold is performed through a button present under the frontal cover and accessible through the hole by using a little screwdriver. The operation has to be performed when the module is correctly supplied. It will be necessary to follow the next procedure:

- Pressed and released the button, the primary output starts to represent the value of threshold. At this point the red led flashes slowly.
- If within 5 seconds there is no pression, the system returns to the normal functioning.
- On the contrary at every further pressure, there is an increment or decrement of approximately 0,2 %; the direction of the variation depends on the Normal state of the output and therefore on the dip-switch SW2.7 so that the commutation occurs exactly at the set value, leaving the effect of the hysteresis only at the reset.
- If the button is not released but continues to be pressed, after 2 seconds a continuous increment of 3% starts.
- Reached the maximum/minimum value of the chosen scale, the cycle starts again.
- During the regulation of the threshold, the auxiliary output follows the normal functioning, opening and closing, as previously set.
- After 5 seconds of button's inactivity, the set value is memorized and the instrument continues with the normal functioning.

#### Note:

The threshold may not be modified in case of internal fault. If the power supply is not sufficient during the regulation or before the 5 seconds of button's inactivity are elapsed, the new value will not be memorized.

#### Details of Dip-Switch SW2.7

SW2.7	Regulation Type	Fault	Normal State	Set Threshold
OFF	Furnace (*)	Towards the high	Closed (led ON)	Decrement
ON	Refrigerator (*)	Towards the bottom	Opened (led OFF)	Increment

(\*) In case of choice of direct output (0/4..20 mA), 0/1..5/10 V)

**Installation rules**

This module has been designed for assembly on a DIN 46277 rail. Assembly in vertical position is recommended in order to increase the module's ventilation, and no raceways or other objects that compromise aeration must be positioned in the vicinity. Do not position the module above equipment that generates heat; we recommend positioning the module in the lower part of the control panel or container compartment. We recommend rail-type assembly using the corresponding bus connector (Code K-BUS)

Inserting the module in the rail

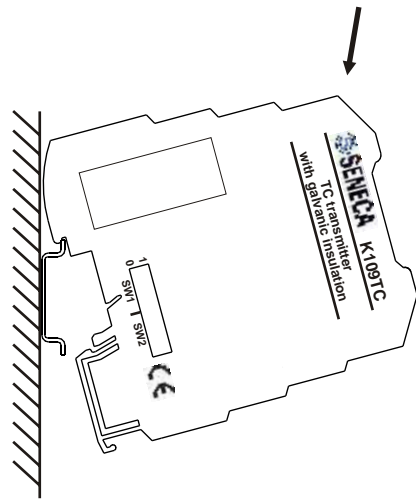

- 1 - Attach the module in the upper part of the rail.
- 2 - Press the module downwards.

Removing the module from the rail

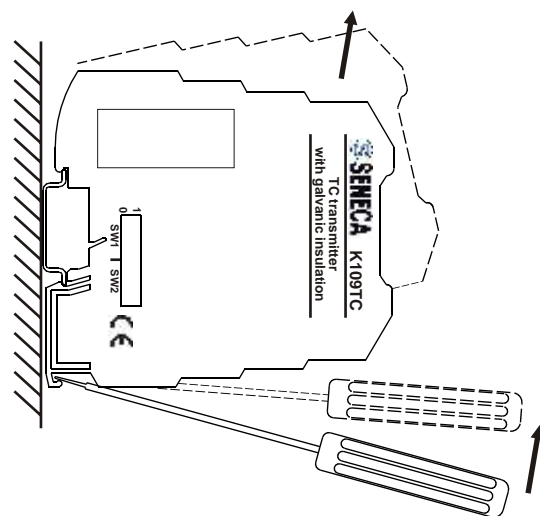

- 1 - Apply leverage using a screwdriver (as shown in the figure).
- 2 - Rotate the module upwards.

**Using the K-BUS**

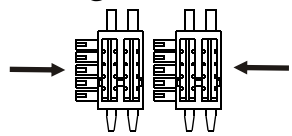

- 1 - Compose the K-BUS connectors as required in order to obtain the number of positions necessary (each K-BUS permits the insertion of no. 2 modules).
- 2 - Insert the K-BUS connectors in the rail by positioning them on the upper side of the rail and then rotating them downwards.

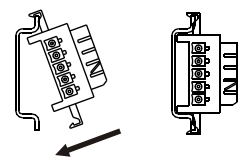

**IMPORTANT:** Pay particular attention to the position of the protrudent terminals of the K-BUS. The K-bus must be inserted in the guide with the protrudent terminals on the left (as shown in the figure) otherwise the modules are turned upside downs.

- Never connect the power supply directly to the bus connector on the DIN rail.
- Never tap power supply from the bus connector either directly or by using the module's terminals.

**SETTING OF THE DIP-SWITCHES**

All the module DIP switches are at pos. 0 as default configuration. This set corresponds to the following default configuration :

- Thermocouple Type : J
- Line Rejection : 50 Hz
- Input Filter : Present
- Measurement Range : 0...1000 °C
- Output Signal : 4..20 mA
- Output Signal in case of fault : Towards the top of the output range
- Over-Range : YES: a 2.5% over-range value is acceptable; a 5% over-range value is considered a malfunction.

Auxiliary Output Threshold : 0% of the nominal scale

It is understood that this configuration is valid only with all the DIP switches at position 0. If also one Dip is moved, it is necessary to set all the other parameter as indicated on the following tables.

Note: for all following tables The indication ● indicates that the DIP-switch is set in Position 1 (ON).

THERMOCOUPLE TYPE			
SW1	1	2	3
			J
	●		K
		●	R
	●	●	S
			T
	●	●	B
		●	E
	●	●	N

LINE REJECTION	
SW1	4
	● 60 Hz
	50 Hz

INPUT FILTER (*)	
SW1	5
	● Present
	Absent

(\*) The input filter stabilizes the measurement and guarantees the repeating of the disturbance signal overlapping the measurement signal but slows down the response time. If the maximum response speed is not required, it is advisable to insert it.

MEASUREMENT RANGE START											
SW1	6	7	8	J Type	K Type	R Type	S Type	T Type	B Type	E Type	N Type
				Default *	0 °C	0 °C	0 °C	0 °C	0 °C	0 °C	0 °C
	●			0 °C	100 °C	100 °C	100 °C	50 °C	400 °C	100 °C	100 °C
		●		100 °C	200 °C	200 °C	200 °C	100 °C	500 °C	200 °C	200 °C
	●	●		200 °C	400 °C	300 °C	300 °C	200 °C	600 °C	300 °C	300 °C
			●	300 °C	600 °C	400 °C	400 °C	-50 °C	800 °C	400 °C	500 °C
	●	●		500 °C	800 °C	600 °C	600 °C	-150 °C	1000 °C	500 °C	700 °C
		●	●	-100 °C	-100 °C	800 °C	800 °C	-100 °C	1200 °C	-100 °C	-100 °C
	●	●	●	-200 °C	-200 °C	1000 °C	1000 °C	-200 °C	1400 °C	-200 °C	-200 °C

\* If all the dip-switches are set to OFF position, the default configuration is valid; otherwise the value of this parameter is 0 °C, as for the other thermocouple types.