



## GENERAL SPECIFICATIONS

- 10 MOSFET outputs with shared negative pole collectively fed with from 6 to 40V DC, current carrying capacity 0.5A, resistive load 0.5A inductive load with maximum switch-on/switch-off cycle frequency of 2 cycles/second.
- Removable terminals with section of 2.5 mm<sup>2</sup>.
- Outputs protected against short-circuit.
- Setting of an output safety status upon starting or whenever communication is lacking.
- Safety time can be set from 10 ms to 2000 s.
- Diagnostics for cut-off loads and short-circuits.
- Measurement of the load power supply voltage.
- Possibility of ON-LINE configuration.
- RS485 serial communication with MODBUS-RTU protocol, maximum 32 nodes.
- 1500V AC output insulation compared to communication bus.
- Power supply and serial connection wiring facilitated by means of a bus that can be housed in the DIN guide.
- Insertion and extraction of bus without interruption of communication or system power supply.
- Communication times below 10 ms (@ 38400 baud).
- Connection distance up to 1200 m.



Disposal of Electrical & Electronic Equipment (Applicable throughout the European Union and other European countries with separate collection programs)

This symbol, found on your product or on its packaging, indicates that this product should not be treated as household waste when you wish to dispose of it. Instead, it should be handed over to an applicable collection point for the recycling of electrical and electronic equipment. By ensuring this product is disposed of correctly, you will help prevent potential negative consequences to the environment and human health, which could otherwise be caused by inappropriate disposal of this product. The recycling of materials will help to conserve natural resources. For more detailed information about the recycling of this product, please contact your local city office, waste disposal service or the retail store where you purchased this product.

This document is property of SENECA srl. Duplication and reproduction are forbidden, if not authorized. Contents of the present documentation refers to products and technologies described in it. All technical data contained in the document may be modified without prior notice Content of this documentation is subject to periodical revision.



Brought to you by **SENECAUK**  
PO Box 1 - Ilkley - West Yorkshire - LS29 8HS  
Tel: 01943 602001- Fax: 01943 816796  
Web: [www.SenecaUK.com](http://www.SenecaUK.com) - Email: [Sales@SenecaUK.com](mailto:Sales@SenecaUK.com)

## TECHNICAL SPECIFICATIONS

Power Supply:	10-40 Vdc, 19-28 Vac 50-60Hz, max 2.5W
Communication port:	Two-wire RS485 with settable speed ( 9600 , 19200 , 38400 , 57600 Baud rate) and type of parity (None, Even, Odd)
Protocol:	Modicon MODBUS RTU
Outputs:	10 MOSFET outputs with shared negative pole collectively fed with from 6 to 40V DC, current carrying capacity 0.5A resistive or inductive load
Ambient conditions:	Temperature: 0..55°C , Min.: 30% Max. 90% humidity at 40°C non-condensing, Installation class II, pollution rating 2
Protection rating:	IP20
Weight, dimensions:	140 g., 100 x 112 x 17,5 mm

## Standards:



The instrument complies with the following standards:  
EN50081-2 (electromagnetic emission, industrial environment)  
EN50082-2 (electromagnetic immunity, industrial environment)  
EN61010-1 (safety)  
All circuits must be insulated with double insulation against circuits under dangerous voltage. The power supply transformer must comply with EN60742 standards for insulation transformers and safety transformers.

## OVERALL DIMENSIONS

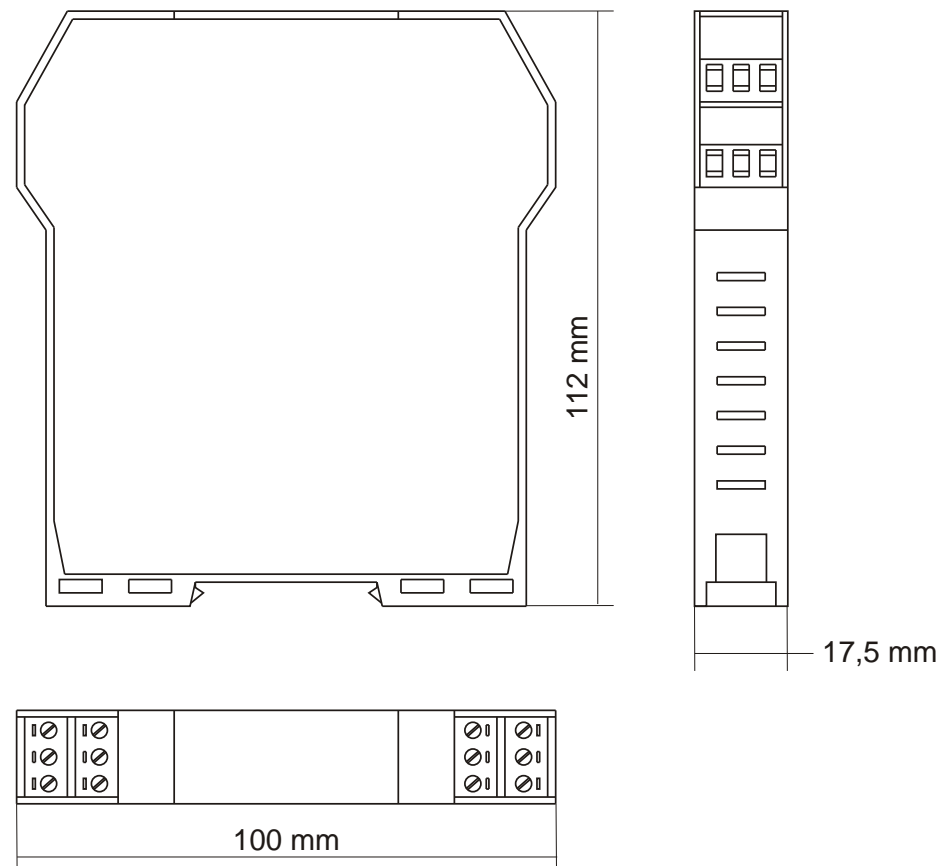

## INSTALLATION

The module has been designed for vertical installation on a DIN 46277 guide.

For optimal operation and long life, adequate ventilation must be provided for the module(s), avoiding positioning channels that obstruct the ventilation louvers.

Avoid fitting modules above equipment that generates heat; you are advised to fit them at the bottom of the panel.

### HARSH OPERATING CONDITIONS:

When the modules are fitted side by side it may be necessary to separate them by at least 5 mm if the panel temperature is above 45°C and operating conditions are harsh.

The following constitute harsh operating conditions:

*High power supply voltage ( > 30Vdc / > 26 Vac ).*

- *Elevated output current .*
- *Frequent commutation of loads that are highly inductive or*
- *incandescent lamps*

*Horizontal assembly.*

•

NOTE: Assembly performed using the appropriate DIN guide connectors ensures the easy assembly and correct ventilation of the modules; see our articles:

- Z-PC-DIN2: 2-position bus
- Z-PC-DIN4: 4-position bus
- Z-PC-DIN8: 8-position bus
- Z-PC-DINAL: termination with terminal boards for RS485 serial communication and power supply.

SYS\_CONF Register:

Bit:	Function:	Writable:
40012.0	If at 0, the timeout is reset by all the module's MODBUS accesses in both reading and writing (default). If 1, the timeout is reset only by the writings in the OUTPUTS (40003) register.	YES
40012.1	If at 0, the load power supply voltage value does not affect the anomaly/malfunction LED (default). If at 1, a load power supply voltage value that is lower than the value in the 'Val threshold' register lights up the anomaly/malfunction LED.	YES
40012.2÷ 40012.7	None, reserved	NO
40012.8÷ 40012.9	Anomaly/malfunction LED enabling mode: 0b00 = always on (default) 0b01 = slow flashing 0b10 = fast flashing 0b11 = double flashing	YES
40012.10÷ 40012.15	None, reserved.	NO

SYS\_CONF2 Register:

Bit:	Function:	Writable:
40016.0÷ 40016.7	Val threshold: comparison value for the load power supply voltage in tenths of Volts. Default 60 -> 6V.	YES
40016.8÷ 40016.15	Delay prior to the recognition of a short-circuit in 1/30 of a second. Default 30 -> 1 second.	YES

## ELECTRICAL CONNECTIONS

### Power supply and RS485 serial communication port

The electrical connections for the power supply and RS485 bus are usually made available by using the bus for the Seneca DIN guide. The connector connections are shown in the figure below:

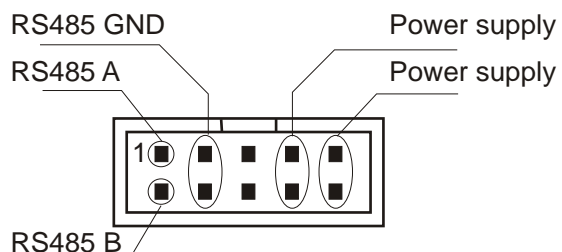

Note: The power supply voltage must be between 10 and 40 Vdc (any polarity) or 19 and 28 Vac; see also section *INSTALLATION*.

The upper limits must not be exceeded as this can seriously damage the module.

The power supply source must be protected against module malfunction by a 0.5A quick-break fuse.

### OUTPUTS

General:

Output status can be set in the Modbus 40003 register. The bits from 0 to 9 in this register indicate respectively the statuses of outputs 1 to 10.

Resistive, inductive or capacitive loads can be connected to the output terminals.

Warning:

- The power supply for these loads MUST be provided directly from terminal 1 (+6V DC = Val = +40V DC). The return currents of the loads MUST be connected together and to terminal 12.
- The total current, the sum of the maximum peak currents of all the loads that can enter from terminal 1 MUST be limited to 8A with quick-break fuse or equivalent protection.

In order to obtain recognition of the output short-circuit, the power supply to the loads must withstand the short-circuit current in the range of 5A to 7A without permitting the voltage to fall below 6V.

- The module keeps the overheating or short-circuit of the outputs under constant control. Whenever an output signals overheating or short-circuit, a time begins running that is set using a configuration parameter (40016.8÷40016.15). If the short-circuit or overheating disappears before this time elapses, the temporary overheating or short-circuit is ignored. If, on the other hand, the temporary overheating or short-circuit remains after this time, the output is disabled and the corresponding bit in Register 40004 is set to zero.

During this period, the protection against overheating by the output transistors connects and disconnects the load in order to keep the temperature within acceptable limits. Overheated or short-circuited outputs are signalled in the respective registers (40007 and 40008).

After an output has been subjected to short-circuit or overheating, the corresponding bit in Register 40004 must be set to zero before it can be re-enabled.

•

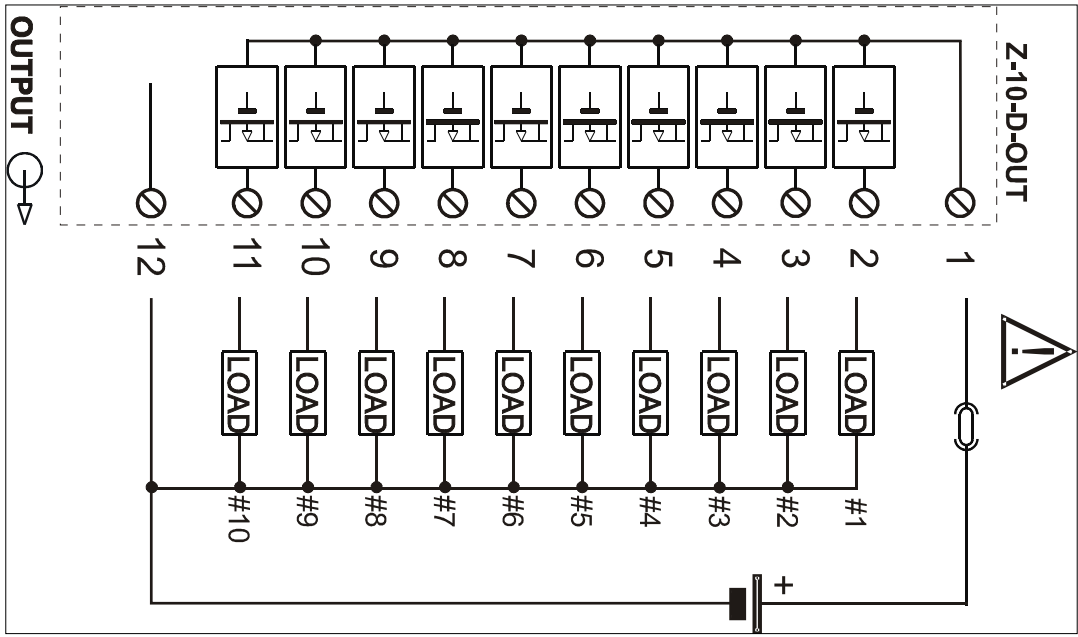

4 : the bit in this register can be read and written also individually using MODBUS controls 1, 5 and 15.

5 : the bit in this register can only be written to zero.

**COM\_CONF1 Register:**

Bit:	Function:	Writable:
40010.0÷ 40010.1	Serial communication parity: 0b00 = none (default) 0b01 = even parity 0b10 = odd parity 0b11 = reserved, do not use	YES
40010.2÷ 40010.7	None, reserved.	NO
40010.8÷ 40010.15	Module MODBUS address.	YES

**COM\_CONF2 Register:**

Bit:	Function:	Writable:
40011.0÷ 40011.7	Delay between request and response in characters (from 0 to 255)	YES
40011.8÷ 40011.10	Serial communication speed: 0b000 = 4800 bps 0b001 = 9600 bps 0b010 = 19200 bps 0b011 = 38400 bps 0b100 = 57600 bps 0b101 = reserved, do not use 0b110 = 1200 bps 0b111 = 2400 bps	YES
40011.11÷ 40011.15	None, reserved.	NO

Address	INITIALS	Function	Mode
40013	<b>SAFETY TIMEOUT</b>	If other than zero, waiting time prior to automatic copying of the DEFAULT OUTPUTS (4005) register in the OUTPUTS (4003) register if the communication is not continuous in 1/30 of a second (minimum 5 seconds). Default: 0 => no automatic reset.	RW
40014	<b>RESERVED</b>	Reserved, do not change.	RO
40015	<b>OPENED MASK</b>	The status of the bit on this register enable, if 1, the control of the cut-off of the corresponding output. Meaning of the single bits: 40012.0 if at 0, output 1 open is ignored in diagnostics 40012.1 if at 0, output 2 open is ignored in diagnostics 40012.2 if at 0, output 3 open is ignored in diagnostics 40012.3 if at 0, output 4 open is ignored in diagnostics 40012.4 if at 0, output 5 open is ignored in diagnostics 40012.5 if at 0, output 6 open is ignored in diagnostics 40012.6 if at 0, output 7 open is ignored in diagnostics 40012.7 if at 0, output 8 open is ignored in diagnostics 40012.8 if at 0, output 9 open is ignored in diagnostics 40012.9 if at 0, output 10 open is ignored in diagnostics 40012.10÷40012.15 bit reserved, ignore the content. Default: 0x0000, all the outputs are ignored.	RW <sup>1,2</sup>
40016	<b>SYS_CONF2</b>	Module configuration. See below for details.	RW <sup>1,2</sup>
40017 ÷40022	<b>RESERVED</b>	Reserved registers: do not modify.	RO
40023	<b>FW RELEASE</b>	firmware version.	RO

## SETTING THE DIP-SWITCHES

One side of the module features the dip-switches which are useful for selecting the following functions:

Communication parameter selection:

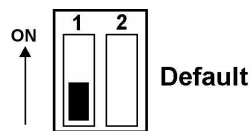

In this position, the following default parameters are utilised (dip-switch 1 = OFF):

Address=001 , Baud Rate=9600 , Parity=none

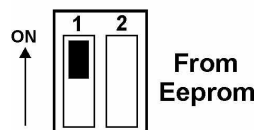

In this position, the parameters memorised inside the Eeprom are utilised. The manufacturer's settings are as follows:

Address=001 , Baud Rate=38400 , Parity=none

When reprogramming the module (when address and speed are not known, for example) it is possible to use the default position that sets the fixed parameters visible in the box.

**NOTE:** At the end of programming, the dip-switch1 must be set to **ON** and the module re-set.

RS485 line termination:

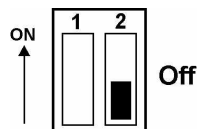

In this position, the termination of the RS485 line is disconnected.

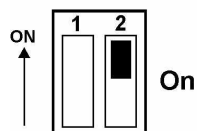

In this position, the termination of the RS485 line is connected.  
**NOTE:** the line must be terminated only at the ends of the communication line.

Note:

- 1 : only a few of the but in the register can be written.
- 2 : the bit reserved must be written with the same value with which they are read.
- 3 : protected register, prior to modifying this value, bit 40002.15 must be set to 1; stopping will be automatically reset 5 minutes after the release operation.

# INDICATIONS ON FRONT

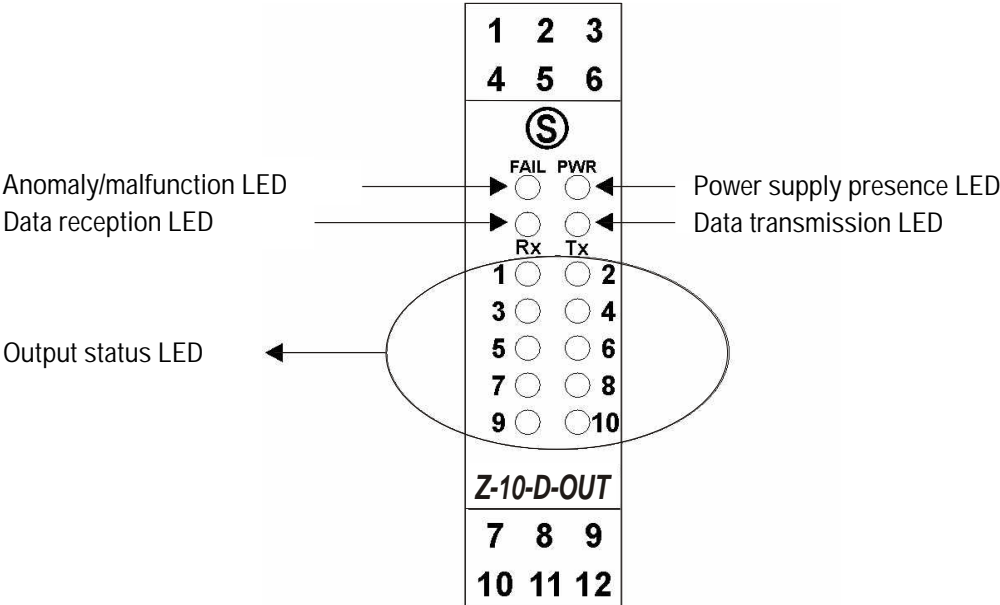

Address	INITIALS	Function	Mode
40004	DIAGNOSTICS	The status of the bit in this register indicate, if 1, the malfunctioning of the corresponding output. Meaning of the single bits: 40004.0 If 1, output 1 is malfunctioning 40004.1 If 1, output 2 is malfunctioning 40004.2 If 1, output 3 is malfunctioning 40004.3 If 1, output 4 is malfunctioning 40004.4 If 1, output 5 is malfunctioning 40004.5 If 1, output 6 is malfunctioning 40004.6 If 1, output 7 is malfunctioning 40004.7 If 1, output 8 is malfunctioning 40004.8 If 1, output 9 is malfunctioning 40004.9 If 1, output 10 is malfunctioning 40004.10÷40004.15 bit reserved, ignore the content The bit set to 1 must be reset to zero before the corresponding output can be re-enabled.	RW <sup>4,5</sup>
40005	DEFAULT OUTPUTS	The content of this register is copied in the OUTPUT (40002) Register when the device is switched on or whenever communication is lacking. Meaning of the single bits: the same as in register OUTPUTS (40002). Default: all the outputs are inactive (0)	RW
40006	OPENED OUTPUTS	The status of the bit in this register indicate, if 1, that the corresponding output is open, when the corresponding bit of the OUTPUTS register is set to 0 and the Val power supply voltage is present.	RO
40007	SHORTED OUTPUTS	The status of the bit in this register indicate, if 1, that the corresponding output is in short-circuit.	RO
40008	HOT OUTPUTS	The of the bit in this register indicate, if 1, that the corresponding output is overheated.	RO
40009	Val VALUE	Output power supply voltage value in tenths of Volt.	RO
40010	COM_CONF1	Address of network and communication configuration. See below for details.	RW <sup>1,2</sup>
40011	COM_CONF2	Communication configuration. See below for details.	RW <sup>1,2</sup>
40012	SYS_CONF	Configuration of the module. See below for details.	RW <sup>1,2</sup>

Address	INITIALS	Function	Mode
40001	<b>MTYPE,VERS</b>  0D02	The MSB of this register contains the module's identification code; the LSB contains its version number. For the module Z-D-OUT we will have: MTYPE=13, VERS=1. The value read is therefore equal to: 0x0D02=3330. It can be used to automatically recognise a module inserted in the bus to replace a faulty one and appropriately re-programme it. Note: the version of the instrument may differ.	RO
40002	<b>STATUS</b>	Status of module. Meaning of single bits: 40002.0 Reading only. If 1, at least one output is in short-circuit 40002.1 Reading only. If 1, at least one output is open 40002.2 Reading only. If 1, at least one output is in overheating 40002.3 Reading only. If 1, errors are present in the status of the outputs and the anomaly/malfunction LED lights up 40002.4÷40002.5 bit reserved, ignore content 40002.6 Reading only. If 1, the voltage is less than the value set in Register 'Val threshold'. If bit 40012.1 in Register SYS_CONF is set to 1, this bit contributes to the switch-on of the anomaly/malfunction LED. 40002.7÷40002.14 bit reserved, ignore content 40002.15 Reading and writing. If 1, writing in the (EEPROM) configuration registers is possible.	RW <sup>1,2</sup>
40003	<b>OUTPUTS</b>	The status of the bits in this register controls the outputs. Meaning of the single bits: 40003.0 controls output 1 40003.1 controls output 2 40003.2 controls output 3 40003.3 controls output 4 40003.4 controls output 5 40003.5 controls output 6 40003.6 controls output 7 40003.7 controls output 8 40003.8 controls output 9 40003.9 controls output 10 40003.10÷40003.15 bit reserved, leave at zero Default: the value contained in register 40005.	RW <sup>4</sup>

## SERIAL INTERFACE

The RS485 serial interface used as the physical support for the MODBUS communication protocol is based on a differential communication line balanced with characteristic impedance of 120Ω.

The maximum length of the connection depends on the Baud Rate, the laying ambient noise, and the type and quality of cable; operation up to 1.2 km is usually guaranteed.

For distances between 15 and 100 m a shielded twisted cable can be used without particular specifications whereas for connections over 100 m you are advised to use, for example, CEAM CPR 6003 or BELDEN 9841 cable.

The connection between "Master" and "Slave" devices is usually made using chain-type configuration with branches from the line limited to a couple of meters, while star branches that make multiple connections to the devices (figure 3) must be avoided.

Especially in longer connections, it is important that the final device "closes" the line, thereby avoiding the phenomena of reverberation: for this purpose, it is sufficient to enable the internal resistance using the dip-switch provided as described below; note that only the head devices (*Master* and *Slave 5* in figure 3) must have the closing resistance active and that the other devices are merely "transiting" the line.

The cable shield must be connected to the GND terminal on both sides and connected to earth on at least one side. If necessary to reduce interference, the other side should be connected to earth by means of a 10 nF capacitor.

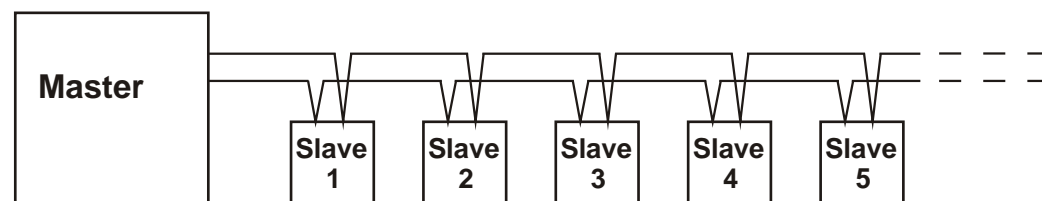

# OK

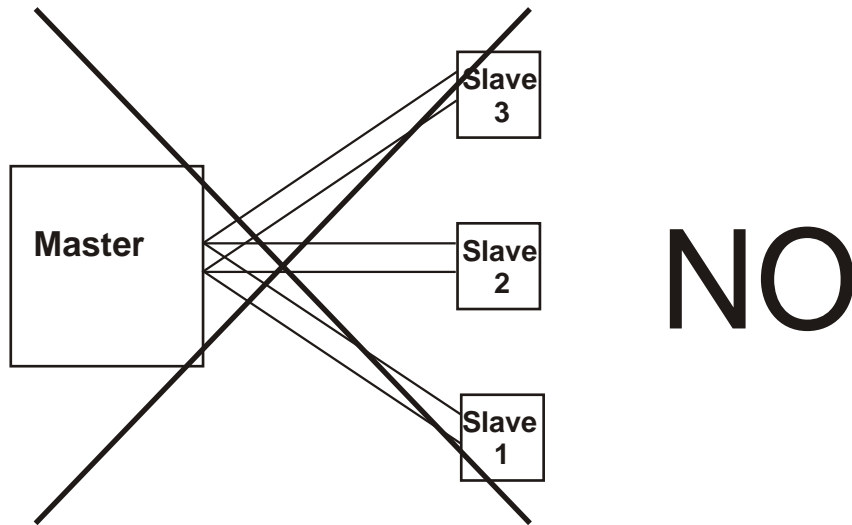
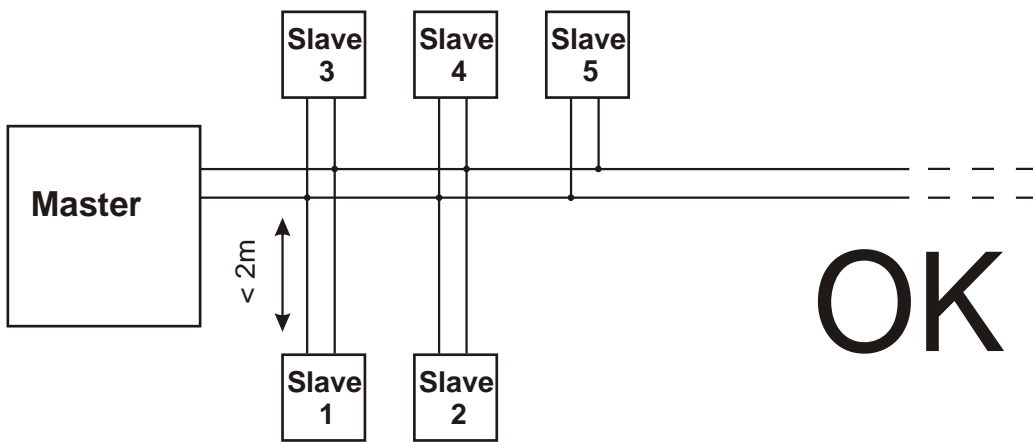

## MODBUS REGISTERS

Below, the numerical values are decimals unless indicated otherwise by the prefix '0x' for hexadecimal values or '0b' for binary values. The suffix (H) indicates the upper part of a word and (L) indicates the lower part. The code 400nn.b indicates the bit b of Register 400nn; for example, 40020.5 indicates bit 5 (counting the least significant from 0) in Register 40020.

NOTE: Whenever an attempt is made to read a data address NOT included in the following tables, the module responds with hexadecimal value 0x3F3F.

Whenever an attempt is made to modify an INVALID data address, the module responds with Error code 2 -> ILLEGAL DATA ADDRESS.

## MODBUS COMMANDS SUPPORTED

Command Code	Description
1 - Read Coils	Reads from the registers as bit fields
3 - Read Holding Register	Reads from the registers up to a maximum of 16 at a time
5 - Write Single Coil	Modifies the status of a single output or other bits
6 - Preset Single Register	Modifies a register
15 - Write Multiple Coils	Writes in the registers as bit fields
16 - Write Multiple Registers	Writes in the registers as bit fields up to a maximum of 14 at a time.

The following table lists and describes the Holding Registers present in the module.

**IMPORTANT:** All the registers below can be easily set using Z-PROG program that can be downloaded from the site: [www.seneca.uk.com](http://www.seneca.uk.com)