

Current / Voltage ⇒ Frequency Converter Z104

GENERAL FEATURES

The current/frequency converter Z104 transforms the current or voltage input signal into a series of pulses of constant duration.

A typical use is when, with a flow meter featuring an analogue output (example 4-20mA), the flow must be totalized.

- current input 0 – 20 mA or 4 – 20 mA with active or passive connection;
- supply of the sensor with 2-wire method: 20VDC stabilized, max. 20mA protected against short-circuiting.
- input in voltage 0 – 5 Vdc, 1 – 5 Vdc, 0 – 10 Vdc and 2 – 10 Vdc;
- integration constant, programmable in the range 1 pulse every 2 hours to 10 KHz;
- straightforward setting, can be performed using a digital multimeter;
- output on npn open-collector transistor and on reed-relay;
- power ON and relay pick-up indicator on front panel;
- 3-point insulation: 1500Vac.

TECHNICAL FEATURES

Power supply:	19 – 40 Vdc, 19-28 Vac 50-60Hz, max 2.5W.		
Input:	Current: 0 – 20 mA or 4 – 20 mA, both active and passive connection Active connection : loop supply voltage approx. 15 Vdc Passive connection : input impedance 100 ohm; Voltage: 0 – 5 Vdc, 1 – 5 Vdc, 0 – 10 Vdc and 2 – 10 Vdc, Input impedance 1 Mohm		
Output:	Npn open-collector transistor 30 Vdc 300 mA Reed-relay 30 Vdc-sc 100 mA		
Environmental conditions:	Temperature: 0..50°C, Humidity min.:30%, max. 90% at 40°C non condensing (also see section entitled Installation instructions).		
Errors referred to the input's range of measurement.	Setting error:	Temperature coefficient:	Linearity error:
	0.2%	0.02%/°C	0.0,5%
Input protection:	continuous 100mA current.		
Output/supply protection:	against impulse overvoltage 400W/ms.		
Standards	The instrument conforms to the following standards: EN50081-2 (electromagnetic emissions, industrial environment) EN50082-2 (electromagnetic immunity, industrial environment) EN61010-1 (safety)		

(*)values to be added to the errors relating to the input selected.



SENECAUK

Web: www.SenecaUK.com Mail: Sales@SenecaUK.com

Tel: 01943 602001 Fax 01943 816796

Z104 module is designed to be mounted on a DIN 46277 bar, in vertical position. To obtain an optimal working and duration, it is necessary to assure an adequate ventilation to modules, avoiding to place raceways or other objects that can close abat-vents. Avoid to mount modules over deviced that generate heat; we suggest to mount devices in the lower side of the panel.

HEAVY WORKING CONDITIONS:

Heavy working conditions are:

- High power voltage a ($> 30Vdc / > 26 Vac$)
- Input sensor feeded.

When modules are put side by side it s possible that it is **necessary to separate them at least 5 mm** in the following cases:

- Upper board temperature higher than 45°C and at least one of the heavy working conditions verified.
- Upper board temperature higher than 35°C and at least two of the heavy working temperature verified.

INPUT SIGNAL SETUP

Set the DIP-switches marked «INPUT» as indicated in the following table:







Current 0 - 20 mA	
Current 4 - 20 mA	
Voltage 0 - 5 Vdc	
Voltage 1 - 5 Vdc	
Voltage 0 - 10 Vdc	
Voltage 2 - 10 Vdc	
SETTING position	

Table 1



SETTING (FOR EXPERT TECHNICAL PERSONNEL ONLY):
THE INSTRUMENT CAN BE SUPPLIED FACTORY SET ON REQUEST.

The instrument can be set using a common digital tester following the procedure explained below:

If the number of pulses/hour to be totalized is P, the scale including the number P must be chosen from the following table and the «RANGE» DIP-switches set to the corresponding position given in table 2:

Table 2 :

FS - IS		FS - IS	
36.000.000 - 8.400.000		2.150 - 520	
9.000.000 - 2.100.000		540 - 130	
2.250.000 - 530.000		135 - 32	
560.000 - 132.000		33 - 8	
140.000 - 33.000		8 - 2	
35.000 - 8.200		2 - 0,5	
8.500 - 2.100			

Table 2

Connect a tester set to the range 10VDC to terminals 1 (-) and 5(+).
 With the input signal disconnected, set the «INPUT» DIP-switches to the SETTING position:
 Turn the setting trimmer until the reading corresponds to the value given by the formula:

$$\text{Voltage reading} = \frac{10 \times P \times K}{FS}$$

where: **P** is the number of pulses/hour to be totalized
K is a setting constant (featured on the instrument's label)
FS is the top of the scale selected in table 2.

When you have finished, reset the «INPUT» DIP-switches (see table 1) to the position corresponding to the output of your sensor.

Example: in order to totalize 90 pulses / hour, set the «RANGE» DIP-switches (on the upper panel) to the configuration given in table 2.

Set the four «INPUT» DIP-switches to the SETTING position.

Turn the setting trimmer until the voltage reading is:

$$\text{Voltage reading} = \frac{10 \times 90 \times 1,05}{135} = 7 \text{ Vcc}$$

In previous formula 1,05 we put factor K printed on the device's label.

When you have finished, reset the «INPUT» DIP-switches (see table 1) to the position corresponding to the output of your sensor.

ELECTRICAL CONNECTIONS

We recommend to use shielded cables to do signals connection; monitor must be connected to a preferential ground for devices. Besides it is a good rule avoid to pass wires near power installation cables like inverters, motors, induction furnaces etc.

POWER SUPPLY

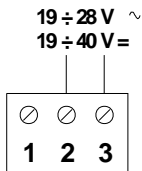

Power voltage must be in a range from 19 to 40 Vdc (indifferent polarity), from 19 to 28 Vac; see also section **INSTALLATION NORMS**.

Upper limits must not be exceeded, if it happen there could be damages for module. It is necessary to protect power source from possible module's failure by fuse correctly dimensioned.

INPUTS

Current with internal loop power supply

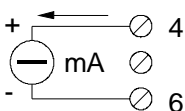

Current with external power supply

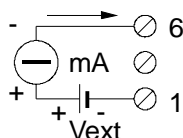

Voltage

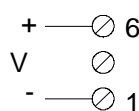

OUTPUTS

Reed-relay
30Vdc-ac 100mA

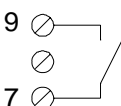

Npn open-collector
30Vdc 300mA

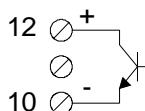

The reed-relay output can only be used with frequencies below 40 Hz.

The reed-relay output is switched on by setting DIP-switch n° 1 of the «RANGE» group to ON.

The transistor output is always on.



UNI EN ISO 9001



CERTIFICATE
Nr. 9115.SENE

SENECAUK

This document is property of SENECAUK. Duplication and reproduction are forbidden, if not authorized. Contents of the present documentation refers to products and technologies described in it. All technical data contained in the document may be modified without prior notice Content of this documentation is subject to periodical revision.

www.SenecaUK.com Sales@senecaUK.com

Tel: 01943 602001 Fax: 01943 816796

SENECAUK

Unit 1 Golden Butts Road

LS29 8HS Ilkley

West Yorkshire

United Kingdom



SENECAUK

Web: www.SenecaUK.com Mail: Sales@SenecaUK.com

Tel: 01943 602001 Fax 01943 816796