



FREQUENCY → CURRENT / VOLTAGE CONVERTER

Z111

GENERAL FEATURES

- Pulse input for all the most commonly-used sensors: mechanical contact, reed, npn with 2 and 4 wires, pnp with 3 wires and 24V DC power supply, Namur, photoelectric, variable reluctance, 24V and TTL pulses
- Maximum frequency from 0.1Hz to 9.99 KHz, selectable fullscale from 1.00Hz to 9.99KHz;
- Full-scale can be easily set using rotating switches;
- Selection of the output mode (0/4.20 mA, 0/1..5V , 0/2..10V) using dip-switches;
- Possibility to set the number of pulses for the calculation of the pulse average;
- Indication of power supply presence and out-of-scale errors provided on front panel;
- 3-point insulation: 1500V AC.

TECHNICAL SPECIFICATIONS

Power supply:	19–40V DC, 19–28V AC 50 – 60 Hz , max 2.5W
Input:	Pulses: mechanical contact, reed , npn with 2 and 3 wires , pnp with 3 wires and 24V DC power supply, Namur, photoelectric, “HALL” sensor, and variable reluctance. Maximum frequency 9.99 KHz
Output:	Active current 0..20 mA / 4..20 mA, max. load resistance: 600 ohm Voltage 0..5V / 0..10V / 1..5V / 2..10V , min. load resistance: 2500 ohm Error : < 0.3% of F.S.
Work conditions:	Temperature: 0 - 50°C , Min. humidity: 30% , Max. humidity: 90% at 40°C (non condensing)
Standards	The instrument conforms to the following standards: EN50081-2 (electromagnetic emission, industrial environments) EN50082-2 (electromagnetic immunity, industrial environments) EN61010-1 (safety)



INSTALLATION RULES

The Z111 modules have been designed for mounting on DIN 46277 guides in vertical position. For long-lasting and optimum working life, the module(s) must be ensured adequate ventilation. Make sure to position the cable raceways and any other objects in such way as to avoid clogging the ventilation slots. Also avoid positioning the modules above equipment that generates heat. For this reason, we recommend performing installation in the lower part of the panel.

TAXING WORK CONDITIONS:

The following are considered taxing work conditions:

- *elevated power supply voltage (> 30V DC / > 26 V AC)*
- *providing power supply to sensor input*
- *use of the active current output.*

When paired modules are installed, **they may require separation by at least 5 mm** in the following cases:

- With panel temperatures of more than 45°C in concomitance with at least one of the taxing work conditions above,
- With panel temperatures of more than 35°C in concomitance with at least two of the taxing work conditions above.



SENECAUK

Web: www.SenecaUK.com Mail: Sales@SenecaUK.com
Tel: 01943 602001 Fax 01943 816796

ELECTRICAL CONNECTIONS

We recommend using shielded cables for the connection of the signals; the shield must be connected to a designated ground connection for the instrumentation. We also discourage passing the wires near the power supply cables for inverters, motors, or induction ovens, etc.

POWER SUPPLY

- 2 — 19 ÷ 28 V~ The power supply voltage must be between 19 and 40 V DC (polarity not important), 19 and 28 V AC; also see the section entitled "**INSTALLATION RULES**".
- 3 — 19 ÷ 40 V= **The upper limits must never be exceeded at the risk of creating serious damage to the module.**
- The power supply source must be protected against all risk of module malfunction by the use of an well sized fuse

INPUTS

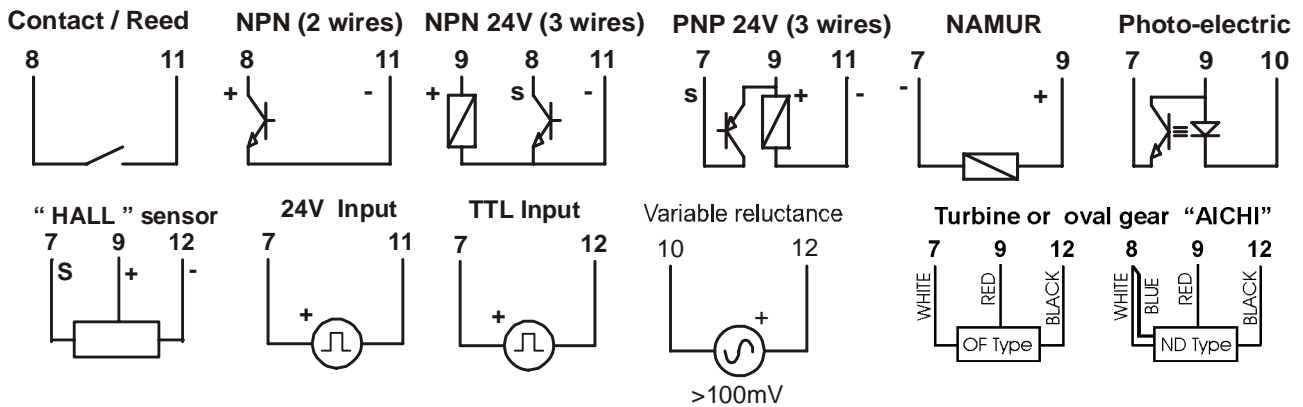

NOTE : In order to permit the use of the variable reluctance type input, the internal jumpers must be selected.

*Before setting the internal jumpers, the container's lateral closing panel must be removed by pulling it slightly outward. The instrument is supplied with internal jumpers set for **standard inputs**.*

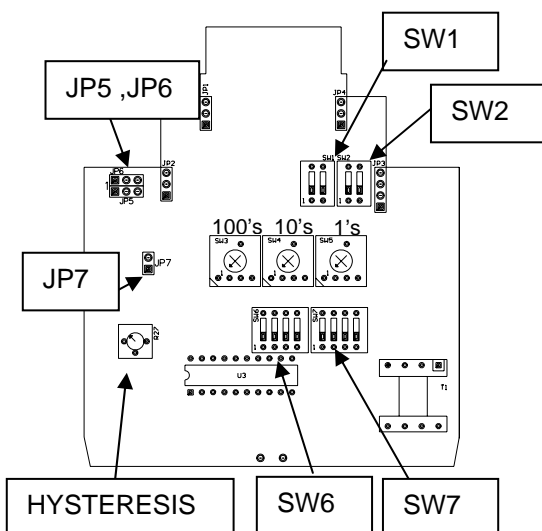

Internal jumper setting for standard inputs:

- JP5 in position 2-3
- JP6 in position 2-3
- JP7 open

Internal jumper setting for variable reluctance inputs:

- JP5 in position 1-2
- JP6 in position 1-2
- JP7 closed

Note: Pin number 1 on jumpers JP5 and JP6 stands on the left while looking at the card from the front.

HYSTERESIS CALIBRATION

This operation is only performed when the "variable reluctance" input is used.

For the hysteresis calibration, after first correctly setting the internal jumpers and the full-scale frequency, a tester must be connected to the device's output (it makes no difference whether the voltage or current output is used) and an input signal must be provided; then using a screwdriver, rotate the hysteresis trimmer completely counter-clockwise (the tester should indicate 0) and then the trimmer must be slowly rotated clockwise until the tester provides a stable input reading. At this point, rotate the trimmer clockwise by around 5% in order to have a sufficient calibration safety margin.

NOTE : remember that the minimum signal amplitude is 100 mV

RETRANSMITTED OUTPUT

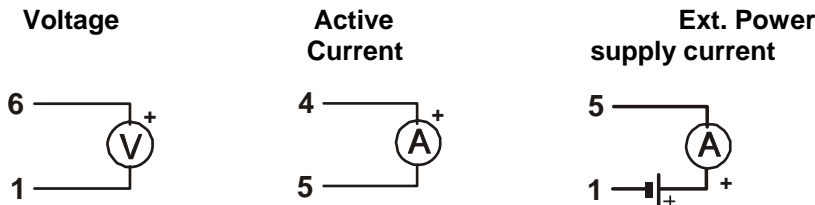

FILTER SETTING

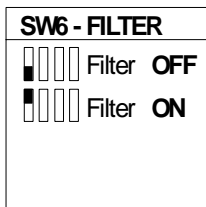

Whenever the input frequency is unstable, a filter can be set to stabilise the output signal. In order to set this filter, position **SW6** dip-switch no. 1 in the **ON** position (by shifting it upwards).

N.B.: The dip-switches must be set after first disconnecting power supply from the module in order to avoid damaging the module.

INPUT FREQUENCY SETTING

The input signal full-scale frequency can be easily set.

The three rotating selectors permit the setting of a value which when multiplied by the multiplication factor will provide the input signal full-scale frequency.

Example 1 : if the input frequency full-scale value = 563 Hz, the hundredths (100's) selector must be set to 5, the tenths (10's) selector must be set to 6, and the units (1's) selector must be set to 3.

The multiplier must be set to x 1 (563 x 1 = 563 Hz).

Example 2 : if the input frequency full-scale value = 7850 Hz, the hundredths (100's) selector must be set to 7, the tenths (10's) selector must be set to 8, and the units (1's) selector must be set to 5.

The multiplier must be set to x 10 (7850 x 10 = 7850 Hz).

NOTE : The hundredths selector (100's) cannot be set to 0; the minimum full-scale value must therefore be 1 Hz

NOTA2: The "Error" led blink if the input frequency is less than 0,1Hz or more than selected fullscale

Multiplier setting

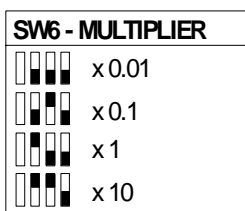

Frequency setting selectors

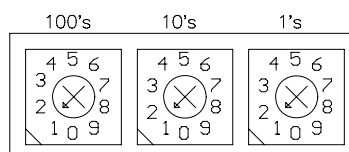

NOTE: Dip-switch and rotating selector setting must be performed after first disconnecting module power supply in order to avoid damaging the module.



SENECAUK

Web: www.SenecaUK.com Mail: Sales@SenecaUK.com
 Tel: 01943 602001 Fax 01943 816796

PULSE AVERAGE SETTING

Whenever the input signals present cyclically unstable frequency, a number of pulses on which the frequency measurement will be calculated can be set.

Example : the input signal is provided by a proximity sensor that indicates the passage of a number of bolts mounted on a wheel; if these bolts are not positioned at equal distances, an unstable sensor output frequency value will occur and this will create an unstable module Z11 output current and/or voltage value.

By setting the number of bolts applied to the wheel, such as 10, for example, as the "pulse average", the device will count 10 pulses and then divide the time that elapses between the first and the last pulse by 10. This operation will permit an extremely stable module output signal to be obtained.

SW7 - PULSE AVERAGE	
	1
	2
	3
	4
	5
	6
	7
	8
	9
	10
	11
	12
	13
	14
	15
	16

NOTE : if pulse average calculation is not required, leave all the **SW7** selector dip-switches **OFF** (shifted down).

NOTE: Dip-switch setting must be performed after first disconnecting module power supply in order to avoid damaging the module.

NOTE: The minimum measured frequency is normally **0.1Hz**. When the pulse average is set over **6**, the minimum frequency will be $n / 60$.
Ex: pulse average = 8 , $f_{\min} = 8/60 = 0.133\text{Hz}$.

OUTPUT SELECTION

SW1 - OUTPUT MODE	
	0..20mA/0..5V/0..10V
	4..20mA/1..5V/2..10V
SW2 - OUTPUT VOLTAGE	
	0/1..5V
	0/2..10V

SW1 unit dip-switches number 1 and 2 permit setting the setting of the output with or without zero elevation respectively.
SW2 unit dip-switches permit the selection of the output voltage.

NOTE: Dip-switch setting must be performed after first disconnecting module power supply in order to avoid damaging the module.



This document is property of SENECAUK. Duplication and reproduction are forbidden, if not authorized. Contents of the present documentation refers to products and technologies described in it. All technical data contained in the document may be modified without prior notice Content of this documentation is subject to periodical revision.

www.SenecaUK.com Sales@senecaUK.com
Tel: 01943 602001 Fax: 01943 816796
SENECAUK
Unit 1 Golden Butts Road
LS29 8HS ilkley
West Yorkshire
United Kingdom