

**Z-4RTD2 CONVERTER FOR THERMO-RESISTORS WITH 6-POINT INSULATION**

**General Description**

The Z-4RTD2 instrument is a digital converter for platinum or nickel thermo-resistors, with four measuring channels, which are independent and insulated among each other from the power supply and from the serial communication line up to 1.5 kV. Furthermore, the module has:

- Facilitated wiring of power supply and serial bus by means of the bus housed in the DIN rail.
- Communication can be configured by DIP-switch or software.
- RS485 serial communication with MODBUS-RTU protocol, 32 nodes maximum.
- Inputs protected against ESD discharges up to 4 kV.
- High acquisition speed.
- In-field re-calibration possible.

Every input has the following characteristics:

- Measurement of thermo-resistors: PT100, PT500, PT1000, NI100, with 4, 3 or 2 wires wiring.
- Measurement of temperature or resistance.
- Filter programmable at eight levels to stabilize reading.
- Rejection programmable at 50 Hz or 60 Hz.
- Measurement available in the following formats: floating point representation, reverse floating-point, fixed dot at 16 bits, in tenths degrees with sign for temperature, tenths Ohms or hundredths Ohms for resistance.
- Three selectable acquisition speeds (two at 13 bit, one at 14 bit).
- Programmable value in case of fault or freezing of last reading.
- Compensation of three wire resistor on the average value of the connection resistor.

**Technical Specifications**

Power supply : 10..40 Vdc or 19..28 Vac (50..60 Hz)  
Consumption : max 0.7 W

Communication Ports : -RS485, 1200..115200 Baud.  
-RS232, 2400 Baud, Address:01, Parity: NO, Stop bits:1, Delay on the answer: NO, Time-out: 3 s MODBUS-RTU

**PT100 Input - EN 60751/A2 (ITS-90)**

Measuring range : -200..650 °C  
Resistance range : 18.5 Ω .. 330 Ω  
Fault signalling : Rx < 18 Ω, Rx > 341 Ω  
Current on sensor : 875 µA Nominal  
Resistance of cables : 20 Ω Maximum per wire

**PT500 Input - EN 60751/A2 (ITS-90)**

Measuring range : -200..750 °C  
Resistance range : 92.5 Ω .. 1800 Ω  
Fault signalling : Rx < 90 Ω, Rx > 1851 Ω  
Current on sensor : 333 µA Nominal  
Resistance of cables : 30 Ω Maximum per wire



**Ingresso PT1000 - EN 60751/A2 (ITS-90)**

Measuring range : -200..210 °C  
Resistance range : 185 Ω .. 1800 Ω  
Fault signalling : Rx < 180 Ω, Rx > 1851 Ω  
Current on sensor : 333 µA Nominal  
Resistance of cables : 30 Ω Maximum per wire

**NI100 Input**

Measuring range : -60..250 °C  
Resistance range : 69 Ω .. 295 Ω  
Fault signalling : Rx < 60 Ω, Rx > 301 Ω  
Current on sensor : 875 µA Nominal  
Resistance of cables : 30 Ω Maximum per wire

**Other features**

ADC : 14 bits or 13 bits on input range.  
Class/Base Precision : 0.05  
Calibration Precision : 0.04 % (1)  
Linearity : 0.025 % (1)  
Thermal Drift : < 50 ppm/K

Insulation Voltage : 1,5 kV between channels, power supply and communication.  
Protection Index : IP20

Environmental conditions : Temperature -10..+65 °C, Saving of parameters in EEPROM guaranteed in range: 0..50 °C.  
Humidity 30..90 % non-condensing.  
Altitude: up to 2000 m a.s.l.  
-20..+85 °C.

Storage temperature : -20..+85 °C.  
Signalling by LED : Power Supply, Fail, RS485 Communication.  
Connections : -Removable 4-way screw terminals, max 1,5 mm<sup>2</sup>, 3,5 mm pitch.  
-Rear IDC10 connector for DIN rail.  
-3.5 mm stereophonic front jack for RS232 (COM) connection.

Box : PBT, black  
Dimensions and weight : 100 x 112 x 17.5 mm, 120 g.

Standards : EN61000-6-4/2002 (electromagnetic emission, industrial environment)  
EN61000-6-2/2005 (electromagnetic immunity, industrial environment)  
EN61010-1/2001 (safety).  
All circuits must be insulated from the other circuits under dangerous voltage with double insulation. The power supply transformer must comply with EN60742: "Insulated transformers and safety transformers".

(1) On resistor, with Full Scale of 350 Ω (PT100, NI100) or 1850 Ω (PT500, PT1000).



**Installation rules**

The module is designed to be installed in vertical position on a DIN 46277 rail. In order to ensure optimum performance and the longest working life, the module(s) must be supplied adequate ventilation and no raceways or other objects that obstruct the ventilation slots.

Never install modules above sources of heat; we recommend installation in the lower part of the control panel.

**Electric connections**

**POWER SUPPLY AND RS485 COMMUNICATION PORT**

The electric connections for power supply and RS485 bus can be made only by using the bus for the Seneca DIN rail.

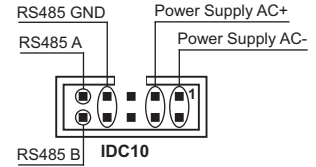

**RS232 SERIAL PORT**

Connection cable DB9 with a 3.5 mm stereo Jack, can be assembled as indicated in the following figure, or can be bought as an accessory.

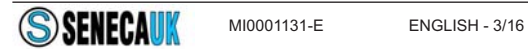
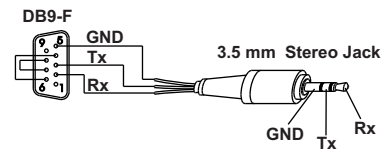

**INPUTS**

The module accepts, at input, temperature probes in platinum and nickel, with 2, 3 or 4 wire connection.

For the electrical connections, we advise you to use screened cables.

**2 Wires Connection**

This connection can be used for short distances (< 10 m) between module and probe. Remember that this connection introduces a measurement error equal to the resistance of the connection cables.

**3 Wires Connection**

A connection to be used for medium-long distances (> 10 m) between module and probe. The instrument compensates the resistance of the connection cables. To ensure correct compensation, the cables must have the same resistance. The compensation is on the average value of the connection resistance.

**4 Wires Connection**

A connection to be used for medium-long distances (> 10 m) between module and probe. It offers maximum precision, in view of the fact that the instrument reads the resistance of the sensor independently from the resistance of the cables.

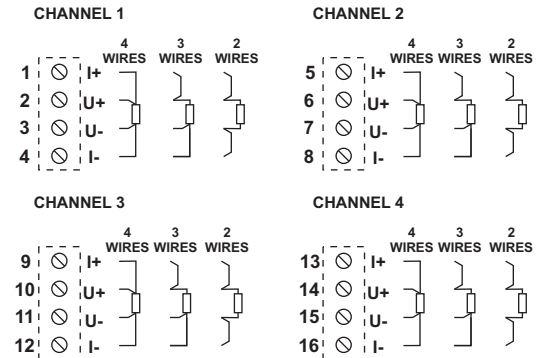

**Programming by LED on the frontal panel**

PWR LED (GREEN)	Meaning
Steady	Power Supply is present.

ERR LED (YELLOW)	Meaning
Steady	Fault: insufficient power supply, faulty channel, faulty sensor, internal communication error (can be de-activated via software).

RX LED (RED)	Meaning
Steady	Data are being received through the RS485 communication port

TX LED (RED)	Meaning
Steady	Data are being transmitted through the RS485 communication port.

**Serial interface**

For detailed information on RS485 serial interface, consult the documentation provided by the website www.seneca.it, in the section **Prodotti/Serie Z-PC/MODBUS TUTORIAL**.

**DIP-SWITCH SETTING**

The instrument leaves the factory with all DIP-switches configured in position 0. The settings of the DIP-switches defines the module's communication parameters: address and speed.

In all the following tables, the indication ● corresponds to a DIP-switch set in 1 (ON); no indication is provided when the DIP-switch is set in 0 (OFF).

<b>SPEED (BAUDRATE)</b>	
SW1	1 2
●	9600 Baud
●	19200 Baud
●	38400 Baud
●	57600 Baud

<b>ADDRESS</b>							
SW1	3	4	5	6	7	8	
							Communication Parameters from EEPROM (2)
							Fixed Address: 01
							Fixed Address: 02
							Fixed Address: 03
							Fixed Address: 04
X	X	X	X	X	X	X	Fixed Address, as from binary representation.
●	●	●	●	●	●	●	Fixed Address: 63

(2) The default configuration is the following: Address 1, 38400, no parity, 1 stop bit.

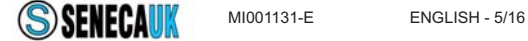

**NOT USED**

SW1	9	Not used
		Leave to OFF position.

**RS485 TERMINATOR**

SW1	10	
		Terminator OFF
		Terminator ON

**FILTER SETTING**

The filtering methods can be set for every channel. The filter consists of two independent low-pass filters:

- Filter FIR, in running average, able to increase the rejection of disturbances to the mains power line frequency and to reduce measuring noise.
- Filter IIR exponential, with programmable time constant, able to dampen fluctuations.

If an input variation higher than the threshold T is detected, both filters are forced to adapt rapidly to the new value, stabilising it only later on. The filter is set with the three least significant bits of registers MODBUS 40037..40 (refer to section **MODBUS REGISTERS**). The following is a table containing all settable filter types. The propagation time (90%) is indicated for each filter, i.e. the maximum time between the step variation of the input and the variation of the number which represents it in the Modbus register, including the interrogation time of an individual register at 115 kbaud). The times indicated apply to the 50 Hz setting - for 60 Hz, divide by 1,2.

SET	SAMPLING		FILTER TYPE	PROP. TIME 90%	
	Bit	ADC Hz		<T (3)	>T (3)
000	13	48	Not Present	45 ms	45 ms
001	13	20	Average	236 ms	103 ms
010 (4)	14	11	Average	405 ms	179 ms
011	14	11	Average + exp	1 s	179 ms
100	14	11	Average + exp	3 s	179 ms
101	14	11	Average + exp	8 s	179 ms
110	14	11	Average + exp	24 s	179 ms
111	14	11	Average + exp	72 s	179 ms

(3) The threshold value depends on the type of RTD:

- T<sub>PT100</sub> = 8 °C
- T<sub>PT500</sub> = 9 °C
- T<sub>PT1000</sub> = 5 °C
- T<sub>NI100</sub> = 5 °C

(4) Default Value.

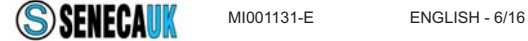

**Programming**

For the products programming and/or configuration tools, consult the website www.seneca.it.

During initial programming, the EEPROM (SW3 .8 in OFF position) default setting values originally programmed as follows can be used:

**Address = 1, SPEED = 38400 baud, PARITY = none, BIT NUMBER = 8, STOP BIT = 1.**

The module can also be programmed through the front connector (COM) while paying attention to set the following connection parameters:

**Address = 1, Speed = 2400 Baud, PARITY = none, STOP BIT = 1.**

The Com communication port behaves in the same way as the RS485 bus port except for the communication parameters described above. It also has priority over the RS485 serial port and closes after 3 seconds of inactivity.

**Calibration procedure**

The Z-4RTD2 module can be calibrated in the field. Document **M1001150.pdf**, containing the calibration procedure can be freely downloaded from site www.seneca.it.

**Frontal panel and Led Position**

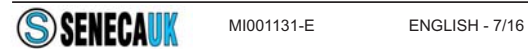
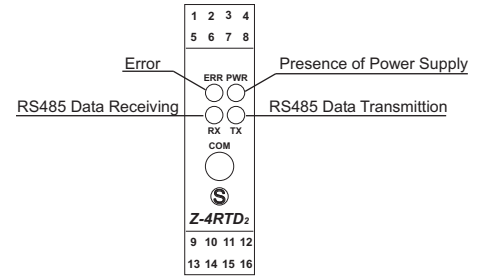

**Dimensions and Overall dimensions**

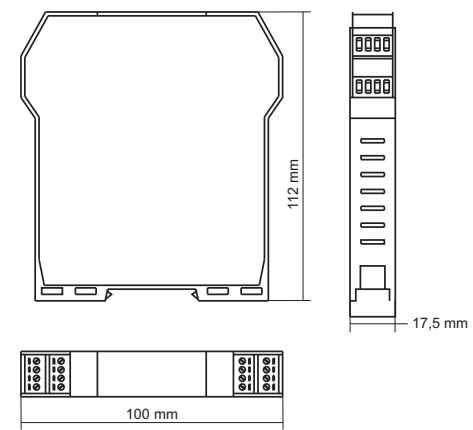

This document is property of SENECA s.r.l. Duplication and reproduction are forbidden, if not authorized. Contents of the present documentation refers to products and technologies described in it. All technical data contained in the document may be modified without prior notice Content of this documentation is subject to periodical revision.

SENECA s.r.l.  
Via Germania, 34 - 35127 - Z.I. CAMIN - PADOVA - ITALY  
Tel. +39.049.8705355 - 8705359 - Fax +39.049.8706287  
e-mail: info@seneca.it - www.seneca.it

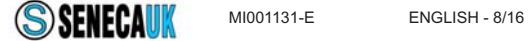

## MODBUS REGISTERS

Z-4RTD2 has MODBUS 16 bits (words) registers, accessible by RS485 or RS232 serial communication. In the next paragraphs, we shall describe the supported MODBUS commands, and the functions of the registers.

### Supported MODBUS Commands

Code	Function	Description
03 (*)	Read Holding Registers	Reading of word registers up to 16 at a time.
04 (*)	Read Input Registers	Reading of word registers up to 16 at a time.
06	Write Single Register	Writing of a word register.
16	Write Multiple Registers	Writing of word registers up to 16 at a time.

(\*) The two functions have the same effect.

### Holding Registers

The 16-bit Holding Registers have the following structure:

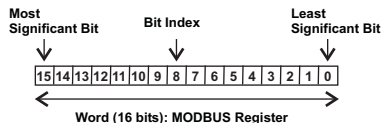

In the table the notation Bit [x:y] indicates all bits from x to y. For example Bit [2:1] indicates bit 2 and bit 1, and serves to illustrate the meaning of the various united combinations of the values of the two bits. Remember that MODBUS functions 3, 4, 6 and 16, of single or multiple writing and reading, can be executed in the following registers. Default values are indicated with the \* symbol.

REGISTER	Description	ADD.	R/W
MACHINE_ID	Bit [15:8]: contain the module's ID: 22. Bit [7:0]: contain the firmware's revision.	40001	R
STATUS_INP	Status of input channels.	40002	R
Bit 15	1: Fault on channel 1.		
Bit 14	1: Fault on channel 2.		
Bit 13	1: Fault on channel 3.		
Bit 12	1: Fault on channel 4.		
Bit 11	1: Fault on sensor of channel 1.		

CHAN1_FLOAT_L	Measurement of channel 1 in floating point (least significant word).	40008	R
Bit [15:0]	Temperature in °C or resistance in Ohms of channel 1 (LSW).		
CHAN2_FLOAT_H	Measurement of channel 2 in floating point (most significant word).	40009	R
Bit [15:0]	Temperature in °C or resistance in Ohms of channel 2 (MSW).		
CHAN2_FLOAT_L	Measurement of channel 2 in floating point (least significant word).	40010	R
Bit [15:0]	Temperature in °C or resistance in Ohms of channel 2 (LSW).		
CHAN3_FLOAT_H	Measurement of channel 3 in floating point (most significant word).	40011	R
Bit [15:0]	Temperature in °C or resistance in Ohms of channel 3 (MSW).		
CHAN3_FLOAT_L	Measurement of channel 3 in floating point (least significant word).	40012	R
Bit [15:0]	Temperature in °C or resistance in Ohms of channel 3 (LSW).		
CHAN4_FLOAT_H	Measurement of channel 4 in floating point (most significant word).	40013	R
Bit [15:0]	Temperature in °C or resistance in Ohms of channel 4 (MSW).		
CHAN4_FLOAT_L	Measurement of channel 4 in floating point (least significant word).	40014	R
Bit [15:0]	Temperature in °C or resistance in Ohms of channel 4 (LSW).		
STATUS_INP	Copy of register 4002 containing the status of the input channels.	40015	R
CHAN1_WIRE	Measurement of channel 1 connection wire.	40016	R
Bit [15:0]	Value of connection wire in mΩ of channel 1.		
CHAN2_WIRE	Measurement of channel 2 connection wire.	40017	R
Bit [15:0]	Value of connection wire in mΩ of channel 2.		
CHAN3_WIRE	Measurement of channel 3 connection wire.	40018	R
Bit [15:0]	Value of connection wire in mΩ of channel 3.		

Bit 7	1: Power supply voltage error (channel 4).		
Bit 6	1: Reception Error (channel 4).		
Bit 5	1: EEPROM saving Error (channel 4).		
Bit 4	1: EEPROM saving blocked (channel 4).		
Bit 3	1: Reading Error of Resistor (Rx) (channel 4).		
Bit 2	1: Reading Error of 3 wire resistor (channel 4).		
Bit 1	1: Acquisition Error (channel 4).		
Bit 0	1: Reading Error CRC EEPROM (channel 4).		
RESET	Module Reset.	40029	R/W
Bit [15:0]	Write value 0xCCCC to reset the module.		
ADDR	Register for the setting of the module's address and parity control.	40035	R/W
Bit [15:8]	Set the module's address. Permissible values from 0x00 to 0xFF (decimal values in the interval of 0-255). Default address: 1.		
Bit [7:0]	Set the type of parity control: 00000000: No parity (NONE) (Default) 00000001: Even parity (EVEN) 00000010: Odd parity (ODD)		
BAUDR	Register for the setting of the Baudrate and the response delay time in characters.	40036	R/W
Bit [15:8]	Set the serial communication speed value (Baudrate): 00000000 (0x00): 4800 Baud 00000001 (0x01): 9600 Baud 00000010 (0x02): 19200 Baud 00000011 (0x03): 38400 Baud (Default) 00000100 (0x04): 57600 Baud 00000101 (0x05): 115200 Baud 00000110 (0x06): 1200 Baud 00000111 (0x07): 2400 Baud		
Bit [7:0]	Set the response delay time in characters that represents the number of pauses of 6 characters each to be entered between the end of the Rx message and the start of the Tx message. Default value: 0.		

Bit 5	Type of returned Data Item : 0: Measurement in °C *. 1: Measurement in Ω		
Bit 4	Third wire compensation : 0: NO * 1: YES		
Bit 3	Rejection to mains frequency : 0: 50 Hz * 1: 60 Hz		
Bit [2:0]	Filter (for details, refer to the FILTER SETTING section): 000: Not present 001: Average filter Other settings in FILTER SETTING.		
CONFIG_CH4	Configuration Register for channel 4.	40040	R/W
Bit [15:8]	For internal use, do not modify.		
Bit [7:6]	Sensor Type: 00: PT100 * 10: PT500 01: NI100 11: PT1000		
Bit 5	Type of returned Data Item : 0: Measurement in °C *. 1: Measurement in Ω		
Bit 4	Third wire compensation : 0: NO * 1: YES		
Bit 3	Rejection to mains frequency : 0: 50 Hz * 1: 60 Hz		
Bit [2:0]	Filter (for details, refer to the FILTER SETTING section): 000: Not present 001: Average filter Other settings in FILTER SETTING.		
AUX_SETTINGS	Additional Configuration Register.	40041	R/W
Bit 15	Floating point interpretation : 0 *: The high word of floating point is transmitted first, then the low word. 1 : The low word of floating point is transmitted first, then the high word.		
Bit [14:8]	Reserved and not modifiable.		
Bit 7	Fault on channel 1 signalled by LED : 0 *: a fault on channel 1 is signalled by LED. 1 : a fault on channel 1 is not signalled by LED.		
Bit 6	Fault on channel 2 signalled by LED (as Bit 7)		

Bit 10	1: Fault on sensor of channel 2.		
Bit 9	1: Fault on sensor of channel 3.		
Bit 8	1: Fault on sensor of channel 4.		
Bit 7	1: Communication Error with channel 1.		
Bit 6	1: Communication Error with channel 2.		
Bit 5	1: Communication Error with channel 3.		
Bit 4	1: Communication Error with channel 4.		
Bit 3	1: Init Error on channel 1.		
Bit 2	1: Init Error on channel 2.		
Bit 1	1: Init Error on channel 3.		
Bit 0	1: Init Error on channel 4.		
CHAN1_TENTHS	Channel 1 measurement (tenths of °C or tenths/hundredths of Ohms)(5)	40003	R
Bit [15:0]	Temperature of channel 1 in tenths of °C (or resistance in tenths/hundredths of Ohms).		
CHAN2_TENTHS	Channel 2 measurement (tenths of °C or tenths/hundredths of Ohms)(5)	40004	R
Bit [15:0]	Temperature of channel 2 in tenths of °C (or resistance in tenths/hundredths of Ohms).		
CHAN3_TENTHS	Channel 3 measurement (tenths of °C or tenths/hundredths of Ohms)(5)	40005	R
Bit [15:0]	Temperature of channel 3 in tenths of °C (or resistance in tenths/hundredths of Ohms).		
CHAN4_TENTHS	Channel 4 measurement (tenths of °C or tenths/hundredths of Ohms)(5)	40006	R
Bit [15:0]	Temperature of channel 4 in tenths of °C (or resistance in tenths/hundredths of Ohms).		
CHAN1_FLOAT_H	Measurement of channel 1 in floating point (most significant word).	40007	R
Bit [15:0]	Temperature in °C or resistance in Ohms of channel 1 (MSW).		

CHAN4_WIRE	Measurement of channel 4 connection wire.	40019	R
Bit [15:0]	Value of connection wire in mΩ of channel 4.		
ERR_CH1_CH2	Details of Errors on Channel 1 (MSB), Channel 2 (LSB).	40025	R
Bit 15	1: Power supply voltage error (channel 1).		
Bit 14	1: Reception Error (channel 1).		
Bit 13	1: EEPROM saving Error (channel 1).		
Bit 12	1: EEPROM saving blocked (channel 1).		
Bit 11	1: Reading Error of Resistor (Rx) (channel 1).		
Bit 10	1: Reading Error of 3 wire resistor (channel 1).		
Bit 9	1: Acquisition Error (channel 1).		
Bit 8	1: Reading Error CRC EEPROM (channel 1).		
Bit 7	1: Power supply voltage error (channel 2).		
Bit 6	1: Reception Error (channel 2).		
Bit 5	1: EEPROM saving Error (channel 2).		
Bit 4	1: EEPROM saving blocked (channel 2).		
Bit 3	1: Reading Error of Resistor (Rx) (channel 2).		
Bit 2	1: Reading Error of 3 wire resistor (channel 2).		
Bit 1	1: Acquisition Error (channel 2).		
Bit 0	1: Reading Error CRC EEPROM (channel 2).		
ERR_CH3_CH4	Details of Errors on Channel 3 (MSB), Channel 4 (LSB).	40026	R
Bit 15	1: Power supply voltage error (channel 3).		
Bit 14	1: Reception Error (channel 3).		
Bit 13	1: EEPROM saving Error (channel 3).		
Bit 12	1: EEPROM saving blocked (channel 3).		
Bit 11	1: Reading Error of Resistor (Rx) (channel 3).		
Bit 10	1: Reading Error of 3 wire resistor (channel 3).		
Bit 9	1: Acquisition Error (channel 3).		
Bit 8	1: Reading Error CRC EEPROM (channel 3).		

CONFIG_CH1	Configuration Register for channel 1.	40037	R/W
Bit [15:8]	For internal use, do not modify.		
Bit [7:6]	Sensor Type : 00: PT100 * 10: PT500 01: NI100 11: PT1000		
Bit 5	Type of returned Data Item : 0: Measurement in °C *. 1: Measurement in Ω		
Bit 4	Third wire compensation : 0: NO * 1: YES		
Bit 3	Rejection to mains frequency : 0: 50 Hz * 1: 60 Hz		
Bit [2:0]	Filter (for details, refer to the FILTER SETTING section): 000: Not present 001: Average filter Other settings in FILTER SETTING.		
CONFIG_CH2	Configuration Register for channel 2.	40038	R/W
Bit [15:8]	For internal use, do not modify.		
Bit [7:6]	Sensor Type : 00: PT100 * 10: PT500 01: NI100 11: PT1000		
Bit 5	Type of returned Data Item : 0: Measurement in °C *. 1: Measurement in Ω		
Bit 4	Third wire compensation : 0: NO * 1: YES		
Bit 3	Rejection to mains frequency : 0: 50 Hz * 1: 60 Hz		
Bit [2:0]	Filter (for details, refer to the FILTER SETTING section): 000: Not present 001: Average filter Other settings in FILTER SETTING.		
CONFIG_CH3	Configuration Register for channel 3.	40039	R/W
Bit [15:8]	For internal use, do not modify.		
Bit [7:6]	Sensor Type : 00: PT100 * 10: PT500 01: NI100 11: PT1000		

Bit 5	Fault on channel 3 signalled by LED (as Bit 7).		
Bit 4	Fault on channel 4 signalled by LED (as Bit 7).		
Bit 3	Action in case of fault on channel 1 : 0 *: The temperature/resistance value is forced to the programmed fault value. 1 : The temperature/resistance value is frozen at the last acquired value before fault is signalled.		
Bit 2	Action in case of fault on channel 2 (As Bit 3)		
Bit 1	Action in case of fault on channel 3 (As Bit 3)		
Bit 0	Action in case of fault on channel 4 (As Bit 3)		
VAL_FAULT_1	Value loaded in case of fault on channel 1 (expressed as 40003).(5)(6) 8500 * (850 °C)	40042	R/W
VAL_FAULT_2	Value loaded in case of fault on channel 2 (expressed as 40004).(5)(6) 8500 * (850 °C)	40043	
VAL_FAULT_3	Value loaded in case of fault on channel 3 (expressed as 40005).(5)(6) 8500 * (850 °C)	40044	
VAL_FAULT_4	Value loaded in case of fault on channel 4 (expressed as 40006).(5)(6) 8500 * (850 °C)	40045	

(5) Registers 40003, 40006 should be interpreted as follows:  
- In Degree tenths, with sign, when they return a temperature.  
- In Ω tenths, without sign, when they return a resistance for PT1000 or PT500.  
- In Ω hundredths without sign when they return a resistance for PT100 or NI100.

(6) The value in registers 40042, 40045 is copied respectively in registers 40003, 40006, when the corresponding bit in register 40041 is 0. The same value is converted in floating-point, with factor 10 or 100 according to the type of data item returned.

Disposal of Electrical & Electronic Equipment (Applicable throughout the European Union and other European countries with separate collection programs)  
This symbol, found on your product or on its packaging, indicates that this product should not be treated as household waste when you wish to dispose of it. Instead, it should be handed over to an applicable collection point for the recycling of electrical and electronic equipment. By ensuring this product is disposed of correctly, you will help prevent potential negative consequences to the environment and human health, which could otherwise be caused by inappropriate disposal of this product. The recycling of materials will help to conserve natural resources. For more detailed information about the recycling of this product, please contact your local city office, waste disposal service or the retail store where you purchased this product.

This document is property of SENECAUK srl. Duplication and reproduction are forbidden, if not authorized. Contents of the present documentation refers to products and technologies described in it. All technical data contained in the document may be modified without prior notice Content of this documentation is subject to periodical revision.