



Module containing 5 relay digital outputs with MODBUS protocol on RS485 Z-D-OUT

GENERAL SPECIFICATIONS

- 5 SPST relay outputs NO with common line, capacity 5A-250Vac resistive, 2A inductive.
- Pull-out terminals, section 2.5mm².
- Possibility of setting relays as NO or NC (rest status).
- Setting of relay safety status at start-up or in the event of no communication.
- Safety time settable from 50 to 2500 ms.
- Possibility of ON-LINE configuration.
- RS485 serial communication with MODBUS RTU protocol, maximum 32 nodes.
- 2500Vac output insulation with respect to remaining low voltage circuits.
- Power supply and serial connection wiring facilitated by means of a bus that can be housed in the DIN guide. The terminals can still be used.
- Insertion into and removal from bus without interrupting communication or system power supply.
- Communication times below 10 ms (@ 38400 baud).
- Connection distance up to 1200 m.

TECHNICAL SPECIFICATIONS

Power supply:	1940 Vdc, 1928 Vac 50-60Hz, max 2.5W
Communication port:	2 wire RS485 serial with settable speed: 9600, 19200, 38400, 57600 baud
Protocol:	Modicon MODBUS RTU
Output:	5 SPST NO relay outputs with common line
Ambient conditions:	Temperature: 0..55°C, min. humidity 30%, max 90% at 40°C non-condensing
Protection rating:	IP20
Weight, Dimensions:	160 g., 100 x 112 x 17,5 mm
Standards:	The instrument complies with the following standards: EN50081-2 (electromagnetic emission, industrial environment) EN50082-2 (electromagnetic immunity, industrial environment) EN61010-1 (safety)



Disposal of Electrical & Electronic Equipment (Applicable throughout the European Union and other European countries with separate collection programs)
This symbol, found on your product or on its packaging, indicates that this product should not be treated as household waste when you wish to dispose of it. Instead, it should be handed over to an applicable collection point for the recycling of electrical and electronic equipment. By ensuring this product is disposed of correctly, you will help prevent potential negative consequences to the environment and human health, which could otherwise be caused by inappropriate disposal of this product. The recycling of materials will help to conserve natural resources. For more detailed information about the recycling of this product, please contact your local city office, waste disposal service or the retail store where you purchased this product.

This document is property of SENECA srl. Duplication and reproduction are forbidden, if not authorized. Contents of the present documentation refers to products and technologies described in it. All technical data contained in the document may be modified without prior notice Content of this documentation is subject to periodical revision.

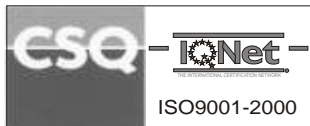

Brought to you by **SENECAUK**
PO Box 1 - Ilkley - West Yorkshire - LS29 8HS
Tel: 01943 602001- Fax: 01943 816796
Web: www.SenecaUK.com - Email: Sales@SenecaUK.com

INSTALLATION

The Z-D-OUT module is designed to be fitted on DIN 46277 guide, in a vertical position.

For optimal operation and long life, adequate ventilation must be provided for the module(s), avoiding positioning channels or other objects that obstruct the ventilation louvers.

Avoid fitting modules above equipment that generates heat; you are advised to fit them at the bottom of the panel.

HARSH OPERATING CONDITIONS:

When the modules are fitted side by side it may be necessary to separate them by at least 5 mm if the panel temperature is above 45°C and operating conditions are harsh.

The following constitute harsh operating conditions:

- High power supply voltage (> 30Vdc / > 26 Vac).
- Sensor power supply at input.

NOTE: Use of the DIN guide connectors ensures practical fitting and correct ventilation of the modules.



Tel: 01943 602001 Fax: 01943 816796

Email: sales@SenecaUK.com

Web: www.SenecaUK.com



ELECTRICAL CONNECTIONS

ALIMENTAZIONE

Power supply

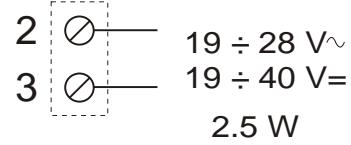

The power supply voltage must be between 19 and 40 Vdc (any polarity) or 19 and 28 Vac; see also section **INSTALLATION**.

The upper limits must not be exceeded as this can seriously damage the module. The power supply source must be protected from any failures in the module by means of a suitably sized fuse. The module can be powered via the DIN guide connectors.

RELAY OUTPUTS

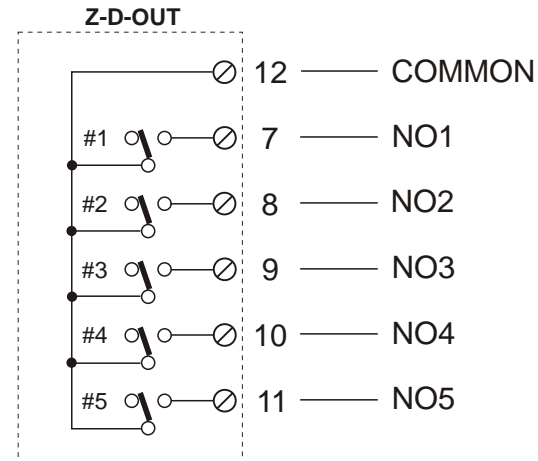

Note: The maximum current that can flow through the **COMMON** terminal is **12A**

BUS RS485

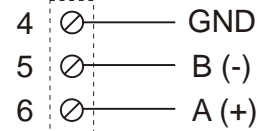

SETTING THE DIP-SWITCHES

One side of the module features the dip switches useful for selecting the following functions:

Communication parameter setting:

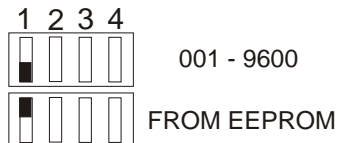

The fixed setting parameters (dip-switch1=OFF) are:
Indirizzo=001 , Baud Rate=9600, Parità = nessuna.

During the first programming it is possible to use the settings from EEPROM (dip-switch **ON**) which are programmed originally with **Address=001** and **Baud Rate=38400**. When reprogramming the module (when address and speed are not known, for example) it is possible to use the default position that sets the fixed parameters visible in the box.

NOTE: At the end of programming, the dip-switch1 must be set to **ON** and the module reset

RS485 line closure setting:



The RS485 line must be terminated only at the ends of the communication line.

Reserved positions:

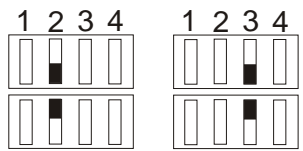

These dip-switch positions are reserved for future use.

40007	STATUS	When set to 1, Bit 40007.0 causes the total resetting of the module. When set to 1 Bit 40007.1 copies Ram registers 40003, 40004, 40005, 40006 into EEPROM registers 40067, 40068, 40069, 40070 .
--------------	---------------	--

MODULE PROGRAMMING EXAMPLE

Example : We wish to programme the module with the following parameters :

- Safety status : activate outputs 2 and 5
- Safety time : 500ms
- Serial communication check : timer reset in data transmission
- Address and baud rate : 002, 9600 baud

By means of a modbus master, the following parameters must be entered in the respective EEPROM locations (the values are expressed in binary notation) :

Address	Value
40067	0b 00000000.00010010 (18 decimal)
40068	0b 00000000.00110010 (50 decimal)
40069	0b 00000000.11000000 (0 decimal)
40070	0b 00000001.00000010 (258 decimal)

After these settings, simply set bit 40007.0 to obtain total reset of the module which will re-start with the new settings.
Operation of the module after the settings: after re-start, the module will activate outputs 2 and 5; the status of the outputs can be changed by setting the appropriate bits of register 40002.
 If serial communication with the module is interrupted (due to a failure or because another module with different address is interrogated) for longer than 500ms, the outputs will be re-set to the safety status.

40003 40067	SAFESTATE	<p>The safety status is set in the bits :</p> <ul style="list-style-type: none"> - output 1: 40003.0 - output 2: 40003.1 - output 3: 40003.2 - output 4: 40003.3 - output 5: 40003.4 <p>This parameter is used to configure a safety position of the relays, if necessary, at switch-on of the module or if there is no serial connection. Set the bits corresponding to the outputs you wish to activate. For activation of the safety status see the EPRFLG register.</p>
40004 40068	SAFETIME 5..250	<p>This is the time that must elapse, if there is no serial connection, before the module sets to the safety status. It can have a value of between 5 and 250 corresponding to a delay from 50ms to 2.5s.</p>
40005 40069	EPRFLG	<ul style="list-style-type: none"> - Bit 40005.0 (*) inverts (if = 1) / or non inverts (if = 0) the relay status. - Bit 40005.2 (*) sets the latency time between the signal and the Modbus response. If bit =0, there will be a delay of 5 ms, if bit =1, there will be a delay of 12 ms. - Bit 40005.3 sets the utilisation of the parity in the data transmission: 0 = no parity, 1 = active parity. - Bit 40005.4 sets the type of parity : 0 = even, 1 = odd. - Bit 40005.6 (*) This parameter is used to select SAFETIME parameter functioning. = 0 it means that SAFETIME timer is reset when the device reads a correct MODBUS function addressed to the device itself. = 1 it means that SAFETIME timer is reset when the device reads a correct MODBUS function addressed to any device on RS485 bus. - Bit 40005.7 (*) enables SAFESTATE = 0 SAFESTATE disable, = 1 SAFESTATE enabled. <p>NOTE: the symbol (*) indicates that the bit modification performed is immediately effective; if this symbol is not present, the module must be reset (after first memorising in EEPROM) in order to enable the modifications.</p>
40006 40070	BAUDR	<p>Communication speed (H) and address (L) of the module. The speed can have the following values:</p> <ul style="list-style-type: none"> 0 = 4800 baud 1 = 9600 baud 2 = 19200 baud 3 = 38400 baud 4 = 57600 baud <p>The address can be between 1 and 255.</p>

SERIAL INTERFACE

The RS485 serial interface is based on a balanced differential communication line with typical impedance of 120 ohm. The maximum length of the connection is not defined but depends on the communication speed, the signal-interference ratio and the cable quality.

Generally the maximum length with guaranteed operation is fixed at 1200 m. The connection cable does not have to be shielded if the distance is only a few metres in a "low noise" electrical environment. For distances between 15 and 100 m a shielded twisted cable can be used without particular specifications whereas for connections over 100 m you are advised to use, for example, CEAM CPR 6003 or BELDEN 9841 cable.

The communication line should preferably be of the chain type, avoiding star configurations and limiting branches to a few metres (see figure below). The ends of the line must be terminated by setting the related dip-sw on the module to ON, or by fitting a resistance of 120 ohm parallel to the line.

The cable shield must be connected to the **GND** terminal on both sides, and connected to earth on at least one side. If necessary to reduce interference, the other side should be connected to earth by means of a 10 nF capacitor.

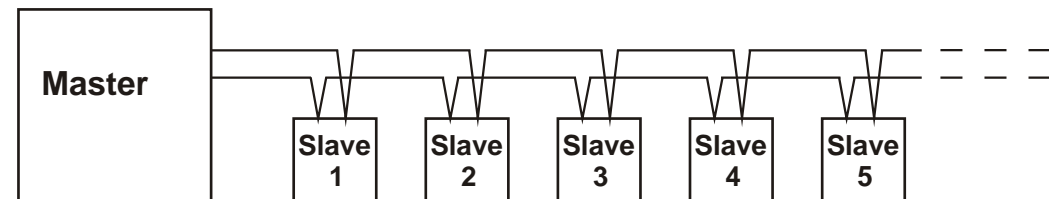

OK

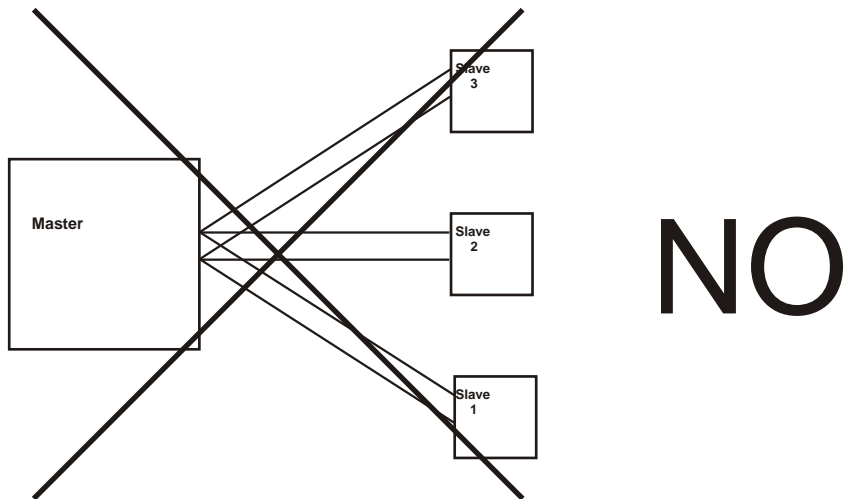
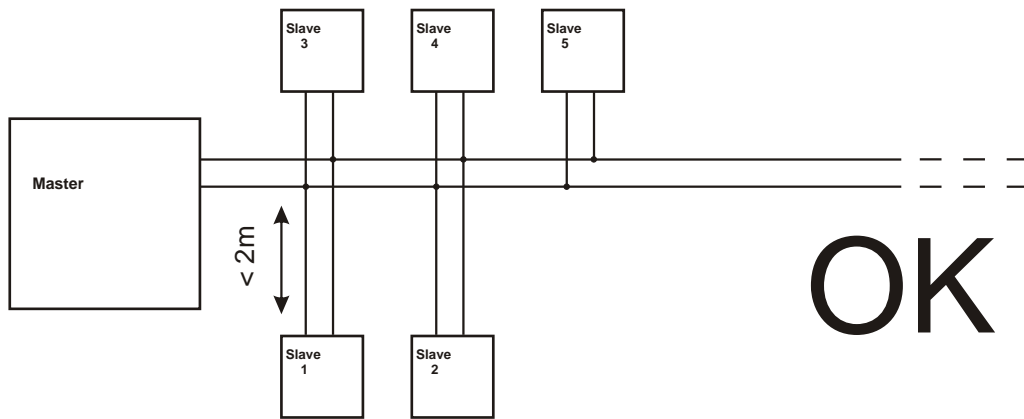

MODBUS REGISTERS

Below, the numerical values are decimals unless indicated otherwise by the prefix '0x' for hexadecimal values or '0b' for binary values. The suffix (H) indicates the upper part of a word and (L) indicates the lower part.

MODBUS COMMANDS SUPPORTED

Command code	Description
3 - Read Holding Register	Permits reading of the RAM and EEPROM registers up to a maximum of 7 at a time.
6 - Preset Single Register	Permits writing of the RAM and EEPROM registers individually.
16 - Preset Multiple Register	Permits writing of the RAM registers up to a maximum of 9 at a time

The following table lists and describes the Holding Registers present in the module.

For many registers the original copy exists in EEPROM. The address of this copy is given by the register number increased by 64. In the table below, for each address the EEPROM address is indicated if present. When the device is switched on (or at reset controlled by serial line) the RAM registers are initialised with the values contained in EEPROM. The EEPROM registers must therefore be programmed for configuration of the module. This configuration can be performed both with the module inserted in the bus together with other modules (obviously with a different address) or with module connected to the PC alone.

Address	Description	Function
40001	MTYPE, VERS 0202	Contains the type (H) and number of the version (L) of the module. For the module Z-D-OUT we will have: type=2, version=2. The value read is therefore worth 0x0202=514. It can be used to automatically recognise a module inserted in the bus to replace a faulty one and appropriately re-programme it. Note: the version of the instrument can vary from the value indicated above according to the revisions and/or updates carried out.
40002	OUTPUT	The outputs are controlled in the bits : <ul style="list-style-type: none"> - output 1: 40002.0 - output 2: 40002.1 - output 3: 40002.2 - output 4: 40002.3 - output 5: 40002.4 The active status of the output is obtained by setting the bits.

OVERALL DIMENSIONS

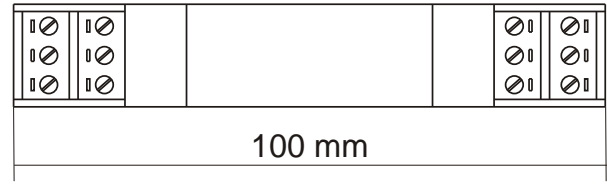
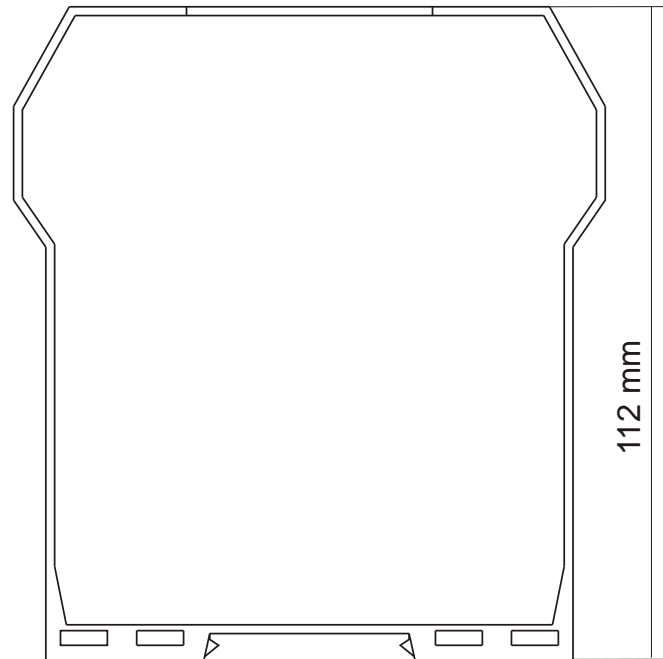

INDICATIONS ON FRONT FASCIA

